



INDIAN INSTITUTE OF TECHNOLOGY, KANPUR

GT ROAD, KALYANPUR, KANPUR – 208016

UTTAR PRADESH, INDIA

TENDER REFERENCE NO.: IITK/DP/NT/2022/01

TENDER DOCUMENTS

For

“Fabrication of an impulse generator assembly”

BID DOCUMENT

The Indian Institute of Technology Kanpur (“the IITK”) invites Bids (“Bids”) from eligible, qualified and capable companies for the supply and delivery of “the Goods” and provision of associated services (“Associated Services”) according to the requirements as defined in the Tender document.

Interested parties may view and download the tender document containing the detailed terms & conditions from the website <http://eprocure.gov.in/eprocure/app>

(The bids must be submitted online in electronic form on www.eprocure.gov.in only. No physical bids will be accepted.)

(A)
INSTRUCTION FOR ONLINE BID SUBMISSION

The bidders are required to submit soft copies of their bids electronically on the Central Public Procurement (CPP) Portal i.e., <http://eprocure.gov.in/eprocure/app> , using valid Digital Signature Certificates. The instructions given below are meant to assist the bidders in registering on the CPP Portal, prepare their bids in accordance with the requirements and submitting their bids online on the CPP Portal.

1. REGISTRATION

- (i) Bidders are required to enroll on the e-Procurement module of the Central Public Procurement Portal (URL:<https://eprocure.gov.in/eprocure/app>) by clicking on the link “Online Bidder Enrolment” option available on the home page. **Enrolment on the CPP Portal is free of charge.**
- (ii) During enrolment/ registration, the bidders should provide the correct/ true information including valid email-id & mobile no. All the correspondence shall be made directly with the contractors/ bidders through email-id provided.
- (iii) As part of the enrolment process, the bidders will be required to choose a unique username and assign a password for their accounts.
- (iv) For e-tendering possession of valid Digital Signature Certificate (Class II or Class III Certificates with signing key usage) is mandatory which can be obtained from SIFY /nCode/eMudra or any Certifying Authority recognized by CCA India on eToken/ SmartCard.
- (v) Upon enrolment on CPP Portal for e-tendering, the bidders shall register their valid Digital Signature Certificate with their profile.
- (vi) Only one valid DSC should be registered by a bidder. Bidders are responsible to ensure that they do not lend their DSCs to others which may lead to misuse and should ensure safety of the same.
- (vii) Bidders can then log into the site through the secured login by entering their userID/ password and the password of the DSC/ eToken.

2. SEARCHING FOR TENDER DOCUMENTS

- (i) There are various search options built in the CPP Portal to facilitate bidders to search active tenders by several parameters. These parameters could include Tender ID, organization name, location, date, value, etc. There is also an option of advanced search for tenders, wherein the bidders may combine a number of search parameters such as organization name, form of contract, location, date, other keywords, etc., to search for a tender published on the CPP Portal.
- (ii) Once the bidders have selected the tenders they are interested in, they may download the required documents / tender schedules. These tenders can be moved to the respective ‘My Tenders’ folder. This would enable the CPP Portal to intimate the bidders through SMS / e-mail in case there is any corrigendum issued to the tender document.
- (iii) The bidder should make a note of the unique Tender ID assigned to each tender, in case they want to obtain any clarification / help from the Helpdesk.

3. PREPARATION OF BIDS:

- (i) For preparation of bid Bidders shall search the tender from published tender list available on site and download the complete tender document and should take into account corrigendum

if any published before submitting their bids.

After selecting the tender document same shall be moved to the 'My favourite' folder of bidders account from where bidder can view all the details of the tender document.

- (ii) Bidder shall go through the tender document carefully to understand the documents required to be submitted as part of the bid. Bidders shall note the number of covers in which the bid documents have to be submitted, the number of documents – including the names and content of each of the document that need to be submitted. Any deviations from these may lead to rejection of the bid.
- (iii) Any pre-bid clarifications if required, then same may be obtained online through the tender site, or through the contact details given in the tender document.
- (iv) Bidders should get ready in advance the bid documents in the required format (PDF/xls/rar/dwf/jpg formats) to be submitted as indicated in the tender document/schedule. **Bid documents may be scanned with 100 dpi with black and white option which helps in reducing size of the scanned document.**
- (v) Bidders can update well in advance, the documents such as experience certificates, annual report, PAN, EPF & other details etc., under "My Space/ Other Important Document" option, which can be submitted as per tender requirements. This will facilitate the bid submission process faster by reducing upload time of bids.

4. SUBMISSION OF BIDS:

- (i) Bidder should log into the site well in advance for bid submission so that he/ she upload the bid in time i.e. on or before the bid submission time. Bidder will be responsible for any delay.
- (ii) Bidder should prepare the EMD as per the instructions specified in the NIT/ tender document. The details of the DD/BC/BG/ others physically sent, should tally with the details available in the scanned copy and the data entered during bid submission time. Otherwise the uploaded bid will be rejected.
- (iii) While submitting the bids online, the bidder shall read the terms & conditions (of CPP portal) and accepts the same to proceed further to submit their bid.
- (iv) Bidders shall select the payment option as offline to pay the EMD and enter details of the DD/BC/BG/others.
- (v) Bidder shall digitally sign and upload the required bid documents one by one as indicated in the tender document.
- (vi) Bidders shall note that the very act of using DSC for downloading the tender document and uploading their offers is deemed to be a confirmation that they have read all sections and pages of the tender document without any exception and have understood the complete tender document and are clear about the requirements of the tender document.
- (vii) Bid documents may be scanned with 100 dpi with black and white option which helps in reducing size of the scanned document. For the file size of less than 1 MB, the transaction uploading time will be very fast.
- (viii) **If price quotes are required in XLS format, utmost care shall be taken for uploading Schedule of quantities & Prices and any change/ modification of the price schedule shall render it unfit for bidding.**

Bidders shall download the Schedule of Quantities & Prices i.e. Schedule-A, in XLS format and save it without changing the name of the file. Bidder shall quote their rate in figures in the appropriate cells, thereafter, save and upload the file in financial bid cover (Price bid) only.

If the template of Schedule of Quantities & Prices file is found to be modified/corrupted in

the eventuality by the bidder, the bid will be rejected and further dealt as per provision of clause no 23.0 of ITB including forfeiture of EMD.

The bidders are cautioned that uploading of financial bid elsewhere i.e. other than in cover 2 will result in rejection of the tender.

- (ix)** Bidders shall submit their bids through online e-tendering system to the Tender Inviting Authority (TIA) well before the bid submission end date & time (as per Server System Clock). **The TIA will not be held responsible for any sort of delay or the difficulties faced during the submission of bids online by the bidders at the eleventh hour.**
- (x)** After the bid submission (i.e. after Clicking “Freeze Bid Submission” in the portal), the bidders shall **take print out of system generated acknowledgement** number and keep it as a record of evidence for online submission of bid, which will also act as an entry pass to participate in the bid opening.
- (xi)** Bidders should follow the server time being displayed on bidder’s dashboard at the top of the tender site, which shall be considered valid for all actions of requesting, bid submission, bid opening etc., in the e-tender system.
- (xii)** All the documents being submitted by the bidders would be encrypted using PKI (Public Key Infrastructure) encryption techniques to ensure the secrecy of the data. The data entered cannot be viewed by unauthorized persons until the time of bid opening. The confidentiality of the bids is maintained using the secured Socket Layer 128 bit encryption technology.

5. ASSISTANCE TO BIDDERS:

- (i)** Any queries relating to the tender document and the terms and conditions contained therein should be addressed to the Tender Inviting Authority for a tender or the relevant contact person indicated in the tender. The contact number of end user is 0512-259-6526. Please call between 10:30 hrs to 17:00 hrs .
- (ii)** Any queries relating to the process of online bid submission or queries relating to CPP Portal in general may be directed to the 24X7 CPP Portal Helpdesk. The 24 x 7 Help Desk Number 0120-4200462, 0120-4001002 and 0120-4001005. The helpdesk email id is support-eproc@nic.in

(B)
INSTRUCTION FOR e-PROCUREMENT

1. PREPARATION AND SUBMISSION OF BIDS:

- a. The detailed tender documents may be downloaded from <http://eprocure.gov.in/eprocure/app> till the last date of submission of tender. The Tender may be submitted online through CPP Portal <http://eprocure.gov.in/eprocure/app>
- b. The bidder should submit the bid online in two parts viz. Technical Bid and Financial Bid. Technical Bid should be upload online in cover 1 and Financial Bid in “.Xls” should be upload online in cover-2

2. SUBMISSION OF THE BID :

All interested eligible bidders are requested to submit their bids online on CPP Portal: <http://eprocure.gov.in/eprocure/app> as per the criteria given in this document:

- a. Technical Bid should be upload online in cover-1.
- b. Financial Bid should be upload online in cover-2

Both Technical and Financial Bid covers should be placed online on the CPP Portal (<http://eprocure.gov.in/eprocure/app>).

3. TECHNICAL BID:

Signed and Scanned copies of the Technical bid documents as under must be submitted online on CPP Portal: <http://eprocure.gov.in/eprocure/app>.

- a. **List of Documents to be scanned and uploaded (Under Cover-1) within the period of bid submission:-**
 - i. Scanned copy of Bank details.
 - ii. Scanned copy of work experience.
 - iii. Scanned copy of certificate of GST.
 - iv. Scanned copy of specifications/brochures & tender acceptance letter on Appendix 1-3.
 - v. Scanned copy of another document mentioned in tender document (if any)
 - vi. Declaration for local content, Country of Origin of goods and Bid Security on Appendix 4-5.
 1. For The tender value upto Rs. 10 Crores - Self-Certificate for local content from the bidder.
 2. For the tender value above Rs. 10 Crores - Certificate for local content from Statutory Auditor/Cost Auditor/Cost Accountant/CA.
- b. **For Import Shipments – Shipping Terms Ex-Works/FOB are preferred.**

NOTE - no indication of the rates/amounts be made in any of the documents submitted with the TC-BID.

4. FINANCIAL BID

- a. The currency of all quoted rates shall be Indian Rupees. All payment shall be made in Indian Rupees.
- b. In preparing the financial bids, bidders are expected to take into account the requirements and conditions laid down in this Tender document. The financial bids should be uploaded online as per the specified “.Xls” format i.e. Price Bid Excel sheet attached as ‘.Xls’ with the tender and based on the scope of work, service conditions and other terms of the Tender

document. It should include all costs associated with the Terms of Reference/Scope of Work of the assignment.

- c. The Financial Proposal should be inclusive of all applicable taxes, duties, fees, levies, and other charges imposed under the applicable laws. The rates quoted in the Tender are inclusive of all applicable taxes, duties etc. **except service tax**. The service tax component shall be re-immersible by the department after receipt of paid challans etc. if applicable.

5. LAST DATE FOR SUBMISSION OF TENDER:

- a. Online bids complete in all respects, must be submitted on or before the last date and time specified in the schedule of events.
- b. The IIT, Kanpur may, at its own discretion, alter/extend the last date for submission of tenders.

6. BID VALIDITY

- a. All the Bids must be valid for a period of 90 days from the last date of submission of the tender for execution of Contract. However, the quoted rates should be valid for the initial/ extended period of the Contract from the effective date of the Contract. No request will be considered for price revision during the original Contract period.
- b. A bid valid for a shorter period shall be declared as non-responsive.
- c. In exceptional circumstances, prior to expiry of the original time limit, the IIT may request the bidders to extend the period of validity for a specified additional period beyond the original validity of 90 days. The request and the bidders' responses shall be made in writing. The bidders, not agreeing for such extensions will be allowed to withdraw their bids without forfeiture of their Bid Security.

7. MODIFICATION / SUBSTITUTION/ WITHDRAWAL OF BIDS:

- a. No Bid shall be modified, substituted or withdrawn by the Bidder after the Bid's due Date.
- b. Any alteration/ modification in the Bid or additional information supplied subsequent to the Bid's due Date, unless the same has been expressly sought for by the Authority, shall be disregarded.

8. REJECTION OF THE BID:

The bid submitted shall become invalid and tender fee shall not be refunded if:-

- a. The bidder is found ineligible.
- b. The bidder does not upload all the documents as stipulated in the bid document.

9. SELECTION CRITERIA:

Phase-I: Technical Evaluation & Sample Approval

Technical evaluation will be done on the basis of information given by technical bid submitted by the bidders. Bid containing partial, incomplete, uncleared and superfluous and unwanted information will be summarily rejected.

Technical declaration must be supported with relevant document. Discrepancy in relevant supporting document and technical compliance sheet shall lead to rejection of technical bids.

Sample Approval:

Bidders should have to display their samples (if asked) on DD.MM.YYYY at the Central Store & Purchase Section of IIT Kanpur. Non-display of sample shall be considered as non-responsive technical bids.

Phase-II

- a. Financial bids of technically qualified and approve samples bidders shall be opened.
- b. Financial evaluation is purely done on the total financial implication.
- c. Any superfluous, unreasonable assets rate quotes will be summarily rejected.

10. Late Delivery:

Delivery must be completed within the period mentioned in tender document from the date of receipt of the order. Penalty @ 1% per week or part thereof subject to a maximum of 10% of the delivery price will be deducted from the balance payment if supply is not completed within stipulated period.

11. Instruction to the bidder of countries which share land border with India (Rule 144(xi) GFRs)

- I. Any bidder from a country which shares a land border with India will be eligible to bid in this tender only if the bidder is registered with the Department for Promotion of Industry and Internal Trade (DPIIT).
- II. "Bidder" (including the term 'tenderer', 'consultant' or 'service provider' in certain contexts) means any person or firm or company , including any member of a consortium or joint venture (that is an association of several persons, or firms or companies) , every artificial juridical person not falling in any of the descriptions of bidders stated hereinbefore, including any agency branch or office controlled by such person, participating in a procurement process.
- III. "Bidder from a country which shares a land border with India" for the purpose of this Order means: -
 - a. An entity incorporated, established, or registered in such a country; or
 - b. A subsidiary of an entity incorporated, established, or registered in such a country; or
 - c. An entity substantially controlled through entities incorporated, established, or registered in such a country; or
 - d. An entity whose beneficial owner is situated in such a country; or
 - e. An Indian (or other) agent of such an entity; or
 - f. A natural person who is a citizen of such a country; or
 - g. A consortium or joint venture where any member of the consortium or joint venture falls under any of the above
- IV. The beneficial owner for the purpose of (iii) above will be as under:
 1. In case of a company or Limited Liability Partnership , the beneficial owner is the natural person(s), who , whether acting alone or together , or through one or more juridical person, has a controlling ownership interest or who exercises control through other means .

Explanation-

- a. "Controlling ownership interest" means ownership of or entitlement to more than twenty-five per cent. of shares or capital or profits of the company.
 - b. "Control" shall include the right to appoint majority of the directors or to control the management or policy decisions including by virtue of their shareholding or management rights or shareholders agreements or voting agreements.
 2. In case of a partnership firm, the beneficial owner is the natural person(s) who, whether acting alone or together, or through one or more juridical person, has ownership of entitlement to more than fifteen percent of capital or profits of the partnership;
 3. In case of an unincorporated association or body of individuals, the beneficial owner is the natural person(s), who, whether acting alone or together, or through one or more juridical person, has ownership of or entitlement to more than fifteen percent of the property or capital or profits of such association or body of individuals ;
 4. Where no natural person is identified under (1) or (2) or (3) above, the beneficial owner is the relevant natural person who holds the position of senior managing official.
 5. In case of a trust, the identification of beneficial owner(s) shall include identification of the author of the trust, the trustee, the beneficiaries with fifteen percent or more interest in the trust and any other natural person exercising ultimate effective control over the trust through a chain of control or ownership .
- V. An Agent is a person employed to do any act for another, or to represent another in dealings with third person.
- VI. In case of tenders for Works contracts, including Turnkey contracts, The successful bidder shall not be allowed to sub-contract works to any contractor from a country which shares a land border with India unless such contractor is registered with the Competent Authority .
12. As per the Ministry of Commerce and Industry Order No. P-45021/2/2017-PP(BE-II) dated 04.06.2020 preference shall be given to Make in India products for which it is mandatory for bidders to declare Country of Origin of goods and percentage of Local contents in the product.

Definitions:

"Local Content" means the amount of value added in India which shall, unless otherwise prescribed by the Nodal Ministry, be the total value of the item procured (excluding net domestic indirect taxes) minus the value of imported content in the item (including all customs duties) as a proportion of the total value, in percent.

"Class-I local supplier" means a supplier or service provider, whose goods, services or works offered for procurement, has local content to or more than 50%, as defined under this order.

"Class-II local supplier" means a supplier or service provider, whose goods, services or works offered for procurement, has local content more than 20% but less than 50%, as defined under this order.

"Margin of purchase preference" means the maximum extent to which the price quoted by a Class-I local supplier may be above the L1 for the purpose of purchase preference. (shall be 20%)

Purchase Preference:

- (a) Subject to the provisions of this Order and to any specific instructions issued by the Nodal Ministry or in pursuance of this Order, purchase preference shall be given to 'Class-I local supplier' in procurements undertaken by procuring entities in the manner specified here under.
- (b) In the procurements of goods or works, which are covered by para 3(b) above and which are divisible in nature, the 'Class-I local supplier' shall get purchase preference over 'Class-II local supplier' as well as 'Non-local supplier', as per following procedure:
 - i. Among all qualified bids, the lowest bid will be termed as L1. If L1 is 'Class local supplier', the contract for full quantity will be awarded to L1.
 - ii. If L1 bid is not a 'Class-I local supplier', 50% of the order quantity shall be awarded to L1. Thereafter, the lowest bidder among the 'Class-I local supplier' will be invited to match the L1 price for the remaining 50% quantity subject to the Class-I local supplier's quoted price falling within the margin of purchase preference, and contract for that quantity shall be awarded to such 'Class-I local supplier' subject to matching the L1 price. In case such lowest eligible 'Class-I local supplier' fails to match the L1 price or accepts less than the offered quantity, the next higher 'Class-I local supplier' within the margin of purchase preference shall be invited to match the L1 price for remaining quantity and so on, and contract shall be awarded accordingly. In case some quantity is still left uncovered on Class-I local suppliers, then such balance quantity may also be ordered on the L1 bidder.
- (c) In the procurements of goods or works, which are covered by para 3(b) above and which are not divisible in nature, and in procurement of services where the bid is evaluated on price alone, the 'Class-1 local supplier' shall get purchase preference over 'Class-II local supplier' as well as 'Non-local supplier', as per following procedure:
 - i. Among all qualified bids, the lowest bid will be termed as L1. If L1 is 'Class-1 local supplier', the contract will be awarded to L1.
 - ii. If L1 is not 'Class-1 local supplier', the lowest bidder among the 'Class-I local supplier', will be invited to match the L1 price subject to Class-I local supplier's quoted price falling within the margin of purchase preference, and the contract shall be awarded to such 'Class-I local supplier' subject to matching the L1 price.
 - iii. In case such lowest eligible 'Class-1 local supplier' fails to match the L1 price, the 'Class-1 local supplier' with the next higher bid within the margin of purchase preference shall be invited to match the L1 price and so on and contract shall be awarded accordingly. In case none of the 'Class-1 local supplier' within the margin of purchase preference matches the L1 price, the contract may be awarded to the L1 bidder.
- (d) "Class-II local supplier" will not get purchase preference in any procurement, undertaken by procuring entities.

13. Bidder will get all benefits under Rule 153 GFR-2017.

(C)

COMMERCIAL TERMS AND CONDITIONS

1. DEFINITIONS

These Commercial Terms and Conditions shall constitute the General Conditions of Contract,

where no separate contract is signed with the selected Bidder(s), and, the Bidders by putting their signature and stamp on each page of this Section V are binding themselves to these Terms and Conditions. In the Commercial Terms and Conditions as defined below, words and expressions shall have the following meanings assigned to them:

- a. "Contract" means the agreement of the Parties relating to the procurement of Goods and / or the IITK Purchase Order (PO), and all attachments incorporated by reference, which shall form an integral part of the Contract. In the event of any discrepancy, the documents to prevail shall be given precedence in the following order: (i) the Contract (where separately signed), (ii) the IITK Purchase Order, (iii) its attachments, and (iv) these Commercial Terms and Conditions;
- b. "Contractor" means the person or entity named in the 'CONTRACTOR' named field of the IITK Purchase Order and any agreed in writing by the IITK legal successor(s) in title;
- c. "Day" means any calendar day;
- d. "Delivery Date" means the latest possible date by which the Goods shall be delivered by the Contractor to the IITK, as specified in the 'DELIVERY DATE' named field of the IITK Purchase Order;
- e. "Force Majeure" shall mean any unforeseeable exceptional situation or event beyond the Parties' control which prevents either of them from fulfilling any of their obligations under the Contract, was not attributable to error or negligence on their part (or of their partners, contractors, agents or employees), and could not have been avoided by the exercise of due diligence. Defects in equipment or material or delays in making them available, labour disputes, strikes or financial problems cannot be invoked as Force Majeure by the defaulting Party. Neither of the Parties shall be held liable for breach of its obligations under the Contract if it is prevented from fulfilling them by Force Majeure. The Party invoking Force Majeure shall notify the other without delay, stating the nature, likely duration and foreseeable effect, and take any measure to minimize possible damage;
- f. "Goods" means all of the goods to be supplied to the IITK by the Contractor under the Contract;
- g. "IITK" means the Indian Institute of Technology Kanpur;
- h. "IITK Purchase Order" means the IITK's official Purchase Order document;
(i) "Party" means the IITK or the Contractor and "Parties" means the IITK and the Contractor; and
(ii) "Place(s) of Delivery" means the location(s) or place(s) where the Goods are to be delivered, as specified in the 'SHIP TO' named field of the IITK Purchase Order.

2. CONCLUSION OF THE CONTRACT

- 2.1. The Contract is made between the IITK and the Contractor. The Contractor is engaged as an independent contractor for the sole purpose of delivering the Goods.
- 2.2. The Contract shall be concluded upon the Contractor duly following the countersigning procedure as stated in the IITK Letter of Intent (LOI).

3. FUNDING

This Contract shall become and remain effective only on the condition that an official Purchase Order is issued by IITK following the conclusion of tender exercise. In the event this is not or no longer shall the case, the IITK without unreasonable delay notify the Contractor thereof.

Any continuation of the Contractor's performance under this Contract after being notified by the IITK shall be at the Contractor's risk and expense.

4. DELIVERY AND TAKE-OVER OF GOODS

The Contractor shall deliver the Goods at the Place(s) of Delivery. On behalf of the IITK, a duly authorised representative(s), shall take-over the Goods upon delivery. Take-over of the Goods by the IITK shall not be deemed acceptance of the Goods by the IITK. The time of delivery as specified in the Contract / PO shall be strictly adhered to, and time shall be of the essence.

5. QUALITY OF GOODS

5.1. The Contractor shall deliver Goods that are:

- a. of the quality, quantity and description as required by the Contract / PO; and
- b. free from any right or claim of a third party, including rights based on industrial property or other intellectual property.

5.2. Should the Goods be of the type "homogeneously defined" or disposable, the Contractor shall provide a sample and undertake, certify, and guarantee that all Goods delivered shall be of the same quality and characteristics as the sample(s) provided.

6. INSPECTION AND ACCEPTANCE

6.1. The duly authorised representative(s) of the IITK shall have the right, before payment, to inspect the Goods either at the Contractor's stores, during manufacture, at the ports and/or in places of shipment, or at the Place(s) of Delivery. The Contractor shall provide all facilities for such inspection. The IITK may issue a written waiver of inspection. Any inspection carried out by representative(s) of the IITK or any waiver thereof shall be without prejudice to other provisions of the Contract concerning obligations assumed by the Contractor, including specifications of the Goods.

6.2. Upon delivery and inspection of the Goods, the IITK shall inspect the goods as soon as possible and complete the Goods Receiving Document. Should any Goods fail to conform to the technical specifications, codes and standards under the Contract, the IITK may reject the Goods. The Contractor shall, at no cost to the IITK, replace the rejected Goods or, alternatively, rectify the non-conformity.

6.3. In the case of Goods ordered on the basis of specifications or samples, the IITK shall have the right to reject the Goods or any part thereof and terminate the Contract if the Goods do not conform to the specifications and/or samples. Nothing in this clause shall in any way release the Contractor from any warranty or other obligations under the Contract.

7. SHIPPING AND INSURANCE

For overseas orders, shipping arrangements shall be co-ordinated by IITK. Original shipping documents including the packing list shall be airtailed/mailed by the Contractor to the (Assistant Registrar (S&P), IIT, Kanpur – 208 016, UP, India).

8. OBSERVANCE OF LAW AND EXPORT LICENCES

The Contractor shall comply with all laws, ordinance, rules and regulations bearing upon the performance of its obligations under the terms of the Contract. If an export licence or any other governmental authorisation is required for the Goods, it shall be the obligation of the Contractor to obtain such licence or governmental authorisation. In the event of the Contractor's failure to obtain such licence or authorisation within a reasonable time, the IITK may immediately terminate the Contract. Where the award procedure or execution of the Contract is vitiated by substantial errors or irregularities or by fraud, the IITK shall suspend execution of the Contract.

Where such errors, irregularities or fraud are attributable to the Contractor, the IITK may also refuse to make payments or may recover monies already paid, in proportion to the seriousness of the errors, irregularities or fraud. The purpose of suspending the Contract shall be to verify whether presumed substantial errors and irregularities or fraud have actually occurred. If they are not confirmed, execution of the Contract shall resume as soon as possible. A substantial error or irregularity shall be any infringement of a contract or regulatory provision of India, resulting from an act or an omission that causes or might cause a financial loss.

9. PRICE

The price of the Goods shall be as stated in the Purchase Order and may not be increased.

10. PAYMENT

- 10.1.** Unless otherwise stipulated in the Purchase Order, the IITK shall make payment within thirty (30) Days of the later of:
- a. Successful delivery of the goods to IITK as confirmed by the consignee (Assistant Registrar, Store & Purchase, IIT-Kanpur), endorsed by the indenter and approved by the indenters' Head of Department / Section;
 - b. Receipt of customary shipping documents and any other documents specified in the Contract; and (c) Receipt of the original invoice issued by the Contractor.
- 10.2.** All invoices shall be in original and shall contain the IITK Purchase Order number, and a description, the quantities, unit and total price(s) of the Goods delivered. The currency of invoice and payment shall be as specified in the Purchase Order. Unless otherwise authorized by the IITK, a separate invoice shall be submitted for each shipment under the Contract / PO. Subject to Clause 11 below ('Tax Exemption'), if applicable, the GST amount shall be separately identified in the invoice.
- 10.3.** Payments shall be made in the currency stated in the Contract / PO, on the basis of the equivalent value of INR on the day of payment and paid directly into the nominated bank account.
- 10.4.** The IITK shall not pay any charge for late payments.

11. TAX EXEMPTION

The Contractor's price shall reflect any tax exemption to which the IITK is entitled. If it is subsequently determined that any taxes that have been included in the price are not required to be paid or if, having been paid, any such taxes are subject to refunding, the IITK shall deduct the amount from the Contract price. Payment of such adjusted amount shall constitute full payment by the IITK. In the event that any taxing authority refuses to recognize the IITK's exemption from taxes, the Contractor shall immediately consult with the IITK to determine a mutually acceptable procedure for settling the applicable amount.

12. WARRANTY

- 12.1.** The Contractor warrants that the Goods furnished under the Contract conform to the technical specifications, description and standards specified in the Contract, and are new and unused, and free from defects in design, workmanship and/or materials.
- 12.2.** The Contractor shall provide a warranty for the Goods for a period of one year from the date of acceptance of the Goods by the IITK unless the standard manufacturer's warranty period is longer in which case the longer period shall apply.
- 12.3.** In the case of "homogeneously defined" or disposable goods, should any portion of the Goods, at any time, not comply with clause 5.1 or 5.2 herein or otherwise prove to be defective, the Contractor shall, upon written notification from the IITK, replace that portion of the Goods and bear all costs associated with the replacement of same.

13. PACKING

- 13.1.** The Goods shall be packed and marked in a proper manner and in accordance with the Contract and any statutory requirements and any requirements of the carrier(s). In particular, the Goods shall be marked with the IITK Purchase Order number and the net, gross and tare weights, the name of the contents shall be clearly marked on each container and all containers of hazardous goods (and all documents relating thereto) shall bear prominent and adequate warnings.
- 13.2.** The Contractor shall provide such packing of the Goods as is required to prevent their damage or deterioration during transit to their final destination. The packing shall be sufficient to withstand, without limitation, rough handling during transit. Packing case size and weights shall take into consideration, where appropriate, the remoteness of the final destination and the absence of appropriate handling facilities at all points in transit.
- 13.3.** All packaging materials shall be non-returnable.

14. DEFAULT AND DAMAGES

- 14.1.** If due to reasons attributable to the Contractor, the Contractor fails or refuses to:
 - a.** deliver any or all of the Goods under the Purchase Order.
 - b.** comply with any or all of the terms and conditions set out in the Purchase Order; or
 - c.** deliver any or all of the Goods under the Purchase Order on or before the Delivery Date; the IITK may hold the Contractor in default under the Purchase Order.
- 14.2.** When the Contractor is thus in default, the IITK may, by written notice to the Contractor, immediately terminate the Purchase Order in whole or in such part or parts thereof in respect of which the Contractor is in default.
- 14.3.** Alternatively, to clause 14 above when the Contractor is thus in default, the IITK may, at its own discretion, set a reasonable period of time for the Contractor to remedy its default. Any new Delivery Date shall be specified in a written amendment to the Purchase Order, duly countersigned by the Contractor.
- 14.4.** The IITK may, at its discretion, impose penalties upon the Contractor calculated in accordance with clause 15 for each Day the Contractor is late in delivering the Goods past the Delivery Date initially specified in the Purchase Order.
- 14.5.** If the Contractor does not remedy its default within the period of time accorded under clause 16, the IITK may, by written notice to the Contractor, terminate the Purchase Order with immediate effect.
- 14.6.** Upon any termination of the Purchase Order, in whole or such part(s) thereof in respect of which the Contractor is in default, the IITK may engage another contractor to deliver the Goods and recover any difference in price and any additional costs from the Contractor.
- 14.7.** The Contractor shall indemnify the IITK for all losses, charges, costs, and expenses, which the IITK may suffer or incur as a result the Contractor's default, including those resulting from engaging another contractor pursuant to this clause 14.

15. PENALTIES

If, in accordance with clause 15, the IITK imposes penalties on the Contractor, such penalties shall amount to One percent (1%) of the total Purchase Order price for each week following the initial Delivery Date specified in the Purchase Order but shall not amount to more than Ten percent (10%) of the total Purchase Order value. The penalties for the delay may be deducted by IITK from any sum(s) due, or to become due, by the IITK to the Contractor.

16. DELAY NOT ATTRIBUTABLE TO THE CONTRACTOR

If the Contractor is delayed at any time in the delivery of the Goods or fulfilment of any other of the Contractor's obligations by any act or omission of the IITK, or by any of its officials, or by any separate contractor(s) contracted by the IITK, or by changes ordered in the type and/or quantity of the ordered Goods, or the Place(s) of Delivery, or any causes beyond the Contractor's reasonable control, or by any other cause, which the IITK determines may

reasonably justify the delay, the Delivery Date of the Goods, or fulfilment of any other of the Contractor's applicable obligations shall be extended for such reasonable period of time as the IITK and the Contractor mutually determine. The set reasonable period of time and any amended delivery date shall be specified in a written amendment to the Contract / PO, duly countersigned by the Contractor.

17. FORCE MAJEURE

As soon as possible after the occurrence of any event constituting Force Majeure, but no later than three (3) Days, the Contractor shall give notice and full particulars in writing to the IITK of the Force Majeure. If the Contractor is thereby rendered unable, wholly or in part, to meet its obligations under the Contract, the IITK may terminate the Contract / PO with immediate effect by providing written notice to the Contractor.

18. INDEMNITY

18.1. The Contractor shall indemnify, hold and save harmless and defend at its own expense the IITK, and all of the foregoing's officials, agents, servants and employees from and against all suits, claims, demands and liability of any nature or kind, including costs and expenses, arising out of acts or omissions of the Contractor or its employees, agents or subcontractors in the performance of the Contract.

18.2. Clause 18 shall include, without limitation, claims and liabilities in the nature of workmen's compensation and claims and liabilities arising out of the use of patented inventions or devices.

19. ASSIGNMENT

19.1. The Contractor shall not assign, transfer, pledge or make other disposition of the Purchase Order or any part thereof or of any of the Contractor's rights, claims or obligations under the Purchase Order except with the express written consent of the IITK. Any assignment made without such consent shall be void and of no effect.

19.2. The Contractor shall not subcontract any of its obligations under the Contract / PO without the express written consent of the IITK. The IITK may require the Contractor to furnish particulars of the proposed subcontract as the IITK deems necessary.

19.3. The IITK's approval of any subcontracting shall not relieve the Contractor from any liability or obligation under the Contract. In any subcontract, the Contractor agrees to bind the subcontractor by the same terms and conditions by which the Contractor is bound under the Contract / PO.

20. INSOLVENCY AND BANKRUPTCY

20.1. Should the Contractor become insolvent or should control of the Contractor change by virtue of insolvency, the IITK may with immediate effect and without prejudice to any other right or remedy available to it, suspend the performance of the Contractor's obligations or terminate the Purchase Order with immediate effect, by providing the Contractor with written notice thereof.

20.2. Should the Contractor be adjudged bankrupt, or should the Contractor make a general assignment for the benefit of its creditors, or should a receiver be appointed on account of the Contractor's insolvency, the IITK may, without prejudice to any other right or remedy available to it, terminate the Purchase Order with immediate effect by providing the Contractor with written notice thereof.

21. TERMINATION

21.1. The IITK shall have the right to terminate the Purchase Order or any of the provisions thereof at any time by serving a three days' notice to the Contractor.

22. WAIVER

A waiver of any breach of or default under the Contract / PO shall not constitute a waiver of any other breach or default and shall not affect the other terms of the Contract / PO. The rights and remedies provided by the Purchase Order are cumulative and are not exclusive of any other rights or remedies.

23. ADVERTISING

The Contractor shall not advertise or otherwise make public the fact that it is a contractor to the IITK. The Contractor shall not in any way use the name, emblem, logo, official seal, or any abbreviation of the IITK.

24. DISCRETION AND CONFIDENTIALITY

The Contractor is required to exercise the utmost discretion in all matters relating to the Contract / Purchase Order. Unless required in connection with the performance of the Purchase Order or expressly authorised in writing by the IITK, the Contractor shall not disclose at any time to any third party any information which has not been made public and which is known to the Contractor by reason of its association with the IITK. The Contractor shall not, at any time, use such information to any private advantage. These obligations do not lapse upon any completion, expiration, cancellation or termination of the Contract / PO.

25. NOTICES

Any notice given in connection with the Contract shall be given in English and in writing and shall be deemed to be validly given if sent by registered mail or by fax or by email to the other Party at the following:

- a. for the IITK: the contact details set out in the 'IITK BUYER' name field of the Purchase Order; and
- b. for the Contractor: the contact details set out in the 'CONTRACTOR' named field of the IITK Contract/Purchase Order.

26. STAFF MEMBERS NOT TO BENEFIT

The Contractor shall not grant to any official of the IITK any direct or indirect benefit or preferential treatment on the basis of the Purchase Order or the award thereof. Any breach of this provision shall constitute a fundamental breach of the Purchase Order.

27. GOVERNING LAW

The Contract shall be governed by and construed in accordance with the substantive laws of the Republic of India.

28. SETTLEMENT OF DISPUTES

- 28.1.** The Parties shall use their best efforts to negotiate and amicably settle any disputes, controversies or claims arising out of, or in connection with, the Contract / Purchase Order or its interpretation.
- 28.2.** If the Parties fail to settle the dispute amicably within thirty (30) Days of commencement of the negotiations, the dispute shall be settled through arbitration. One (1) sole arbitrator shall be appointed by the Director of IITK who shall have full powers to make final and binding decisions subject to prevailing laws of India. The appointing authority shall be the Director of IITK. The place of arbitration shall be Kanpur and the language used in the arbitration proceedings shall be English.

29. PRIVILEGES AND IMMUNITIES

No provision of the Contract / Purchase Order shall be deemed, or interpreted as, a waiver of the privileges and immunities enjoyed by the IITK.

30. AMENDMENTS

No modification, amendment or change to the Contract/Purchase Order, or waiver of any of its provisions, or any additional contractual relationship with the Contractor shall be valid unless approved in the form of a written amendment to the Contract/Purchase Order, signed by a fully authorised representative of each Party.

31. VALIDITY

The invalidity in whole or part of any condition of the Contract / Purchase Order or clause thereof shall not affect the validity of the remainder of such condition or clause.

32. ENTIRE AGREEMENT

The Contract / Purchase Order constitute the entire agreement and understanding of the Parties and supersede any previous agreement, whether orally or in writing, between the Parties relating to the subject matter of the Contract.

33. GOVERNING LANGUAGE

The Contract / Purchase Order shall be executed in the English language which shall be the binding and controlling language for all matters relating to the meaning and interpretation of the Contract / Purchase Order.

TENDER ACCEPTANCE LETTER
(To be given on Company Letter Head)

Date: _____

To,

Sub: Acceptance of Terms & Conditions of Tender.

Tender Reference No: _____

Name of Tender / Work: -

Dear Sir,

1. I / We have downloaded / obtained the tender document(s) for the above mentioned 'Tender/Work' from the web site(s) namely:
_____ as per your advertisement, given in the above mentioned website(s).
2. I / We hereby certify that I / we have read the entire terms and conditions of the tender documents from Page No. _____ to _____ (including all documents like annexure(s), schedule(s), etc .), which form part of the contract agreement and I / we shall abide hereby by the terms / conditions / clauses contained therein.
3. The corrigendum(s) issued from time to time by your department/ organisation too have also been taken into consideration, while submitting this acceptance letter.
4. I / We hereby unconditionally accept the tender conditions of above mentioned tender document(s) / corrigendum(s) in its totality / entirety.
5. I / We do hereby declare that our Firm has not been blacklisted/ debarred/ terminated/ banned by any Govt. Department/Public sector undertaking.
6. I / We certify that all information furnished by our Firm is true & correct and in the event that the information is found to be incorrect/untrue or found violated, then your department/ organisation shall without giving any notice or reason therefore or summarily reject the bid or terminate the contract, without prejudice to any other rights or remedy including the forfeiture of the full said earnest money deposit absolutely.

Yours Faithfully,
(Signature of the Bidder, with Official Seal)

Appendix -2

Certificate for Tender
(To be given on Company Letter Head)

Date: _____

To,

Sub: Certificate of compliance as per Rule 144 (xi) GFR's 2017

Tender Reference No: _____

Name of Tender / Work: -

"I have read the clause regarding restrictions on procurement from a bidder of a country which shares a land border with India; I certify that this bidder is not from such a country or, if from such a country, has been registered with the Competent Authority. I hereby certify that this bidder fulfils all requirements in this regard and is eligible to be considered. [Where applicable, evidence of valid registration by the Competent Authority shall be attached.]"

Yours Faithfully,
(Signature of the Bidder, with Official Seal)

Certificate for Tender for Works involving possibility of sub-contracting
(To be given on Company Letter Head)

Date: _____

To,

Sub: Certificate of compliance as per Rule 144 (xi) GFR's 2017

Tender Reference No: _____

Name of Tender / Work: -

"I have read the clause regarding restrictions on procurement from a bidder of a country which shares a land border with India and on sub-contracting to contractors from such countries; I certify that this bidder is not from such a country or, if from such a country, has been registered with the Competent Authority and will not sub-contract any work to a contractor from such countries unless such contractor is registered with the Competent Authority. I hereby certify that this bidder fulfills all requirements in this regard and is eligible to be considered. [Where applicable, evidence of valid registration by the Competent Authority shall be attached.]"

Yours Faithfully,
(Signature of the Bidder, with Official Seal)

Declaration for Local Content

(To be given on Company Letter Head - For tender value below Rs.10 Crores)

(To be given by Statutory Auditor/Cost Auditor/Cost Accountant/CA for tender value above Rs.10 Crores)

Date: _____

To,
The Director,
Indian Institute of Technology Kanpur,
GT Road, Kalyanpur, Kanpur -208016

Sub: Declaration of Local content

Tender Reference No: _____

Name of Tender / Work: - _____

4. Country of Origin of Goods being offered: _____
5. We hereby declare that items offered has ____% local content.

“Local Content” means the amount of value added in India which shall, be the total value of the item being offered minus the value of the imported content in the item (including all customs duties) as a proportion of the total value, in percent.

*“*False declaration will be in breach of Code of Integrity under Rule 175(1)(i)(h) of the General Financial Rules for which a bidder or its successors can be debarred for up to two years as per Rule 151 (iii) of the General Financial Rules along with such other actions as may be permissible under law.”*

**Yours Faithfully,
(Signature of the Bidder, with Official Seal)**

Bid Security Declaration
(To be given on Company Letter Head)

Date: _____

To,
The Assistant Registrar
Central Stores
IIT Kanpur-208016

Sub: Certificate for bid security declaration

Tender Reference No : _____

Tender ID : _____

Name of Tender / Work: -

"I/We have read the clause regarding Bid Security Declaration/Earnest Money Deposit and I/We are fully aware that if I/We withdraw or modify the bid during the period of validity I may be suspended for a period of 3 years ."

Yours Faithfully,
(Signature of the Bidder, with Official Seal)

INDIAN INSTITUTE OF TECHNOLOGY KANPUR
Dhwaniki Laboratory

Dr. Nachiketa Tiwari
Dhwaniki Labs
IIT Kanpur
Kanpur 208016, U.P

Tel No: +91-512-6526

Quotations are required for fabrication of an impulse generator assembly with details as provided in attached drawing.

Requirements from the vendor

- Vendor should be based in Kanpur. In case the vendor is based out of Kanpur, he should have an established operation in Kanpur.
- Vendor should provide compliance report for all dimensions as specified in the drawing.
- Payment Terms: 100% After delivery of parts, and after satisfactory performance of seals.
- Contract Period: One time.
- Scope of work: Please see attached drawing and RFQ.
- Dimensions associated with sealing functions to sustain hydraulic pressure are somewhat tentative. The vendor, after due consultation with us, may modify these dimensions. This flexibility is provided to ensure proper sealing functionality.

Professor Nachiketa Tiwari
In-charge, Dhwaniki Labs

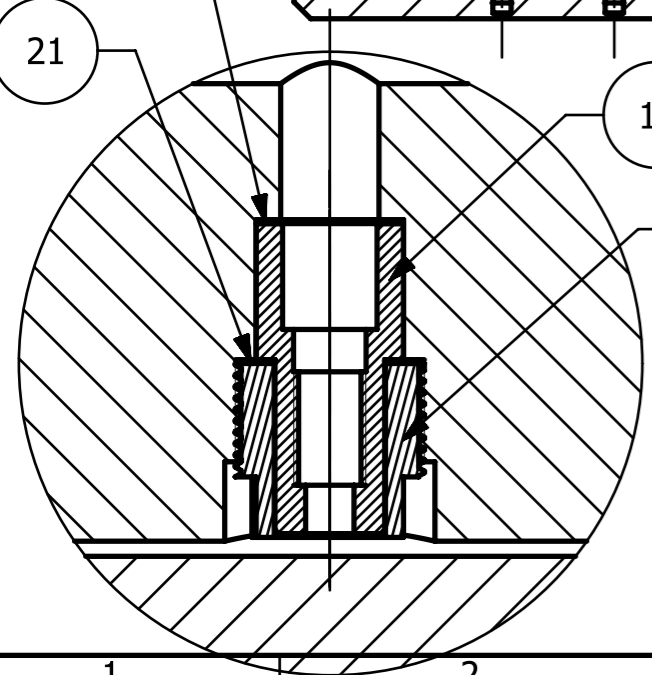
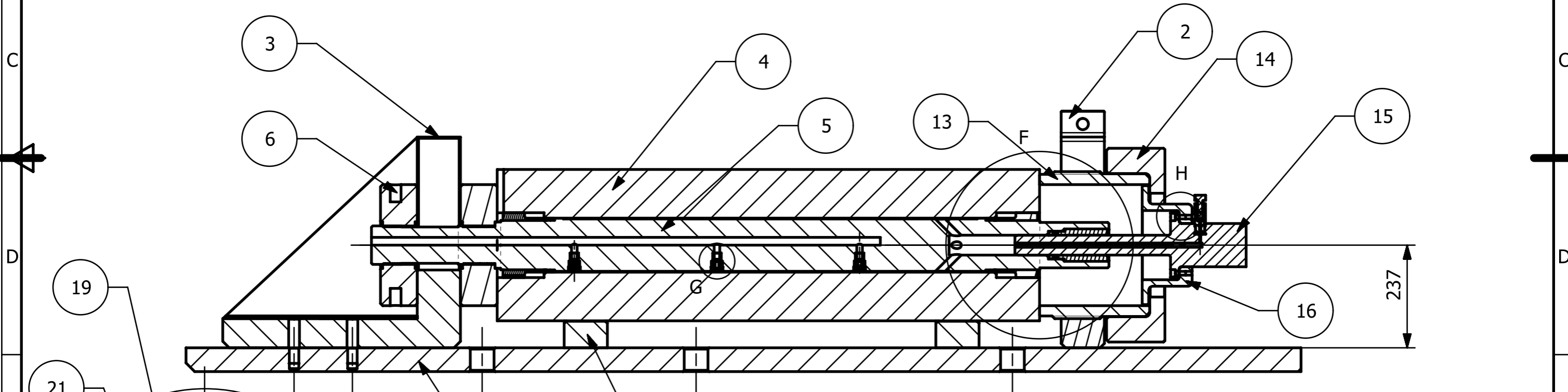
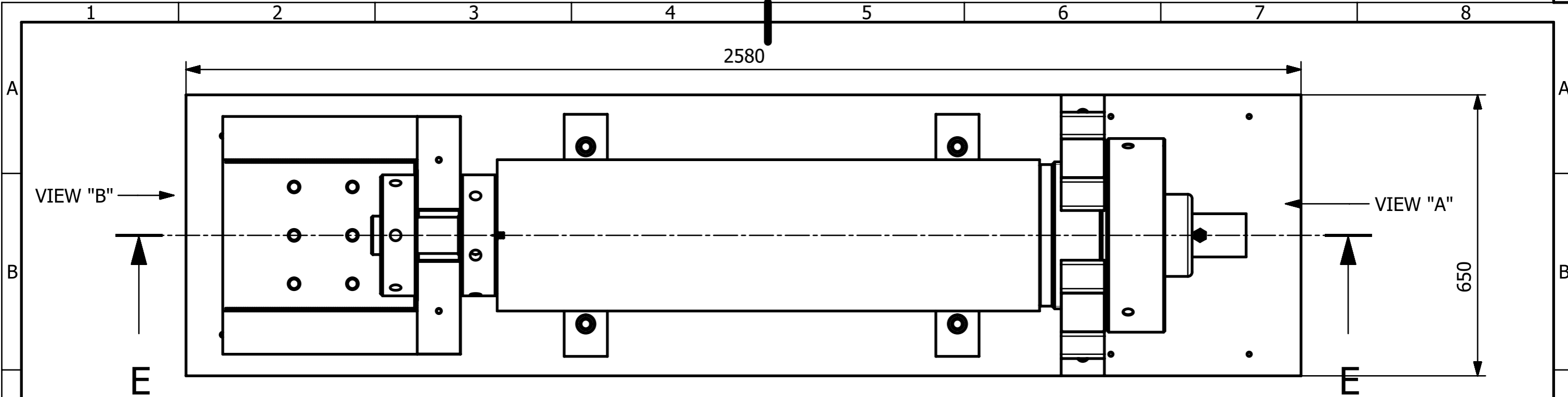

SECTION E-E

DETAIL G
SCALE 1:1

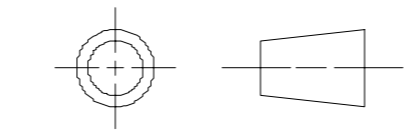

ALL DIMENSIONS IN MM

I.I.T KANPUR			
FIRST ISSUED		TITLE	
DRAWN BY			
CHECKED BY			
APPROVED BY		SIZE	DWG NO.
		A3	IMPULSE PRESSURE GENERATOR Dwg
		SCALE 1:1	SHEET 1 OF 4
			SHEET REV
			A

PART NO	PART NAME	Qty
1	BASE PLATE	1
2	FRONT NUT	1
3	BACK SUPPORT	1
4	BARREL	1
5	INNER CORE	1
6	BACK CHUCK NUT	2
7	STATIC BRASS SEAL	2
8	STATIC P.T.F.E SEAL	2
9	DYNAMIC SEAL GUIDE	1
10	DYNAMIC S.S SEAL	1
11	DYNAMIC P.T.F.E SEAL	1
12	STATIC SEAL GUIDE	2
13	FRONT BOLT	1
14	FRONT BOLT COVER	1
15	PISTON	1
16	PISTON-MASS	1
17	LOWER CLAMP	2
18	SENSOR HOLDER	3
19	LOWER SEAL WASHER	3
20	SENSOR HOLDER THREADED PART	3
21	UPPER SEAL WASHER	3
22	BLEED SCREW	1
23	BALL FOR BLEED ASSEMBLY	1
24	P.T.F.E SEAL FOR BLEED ASSEMBLY	1
25	O-RING BLEED ASSEMBLY	1
26	DYNAMIC BRASS SEAL	1
27	BLEED HOUSING	1

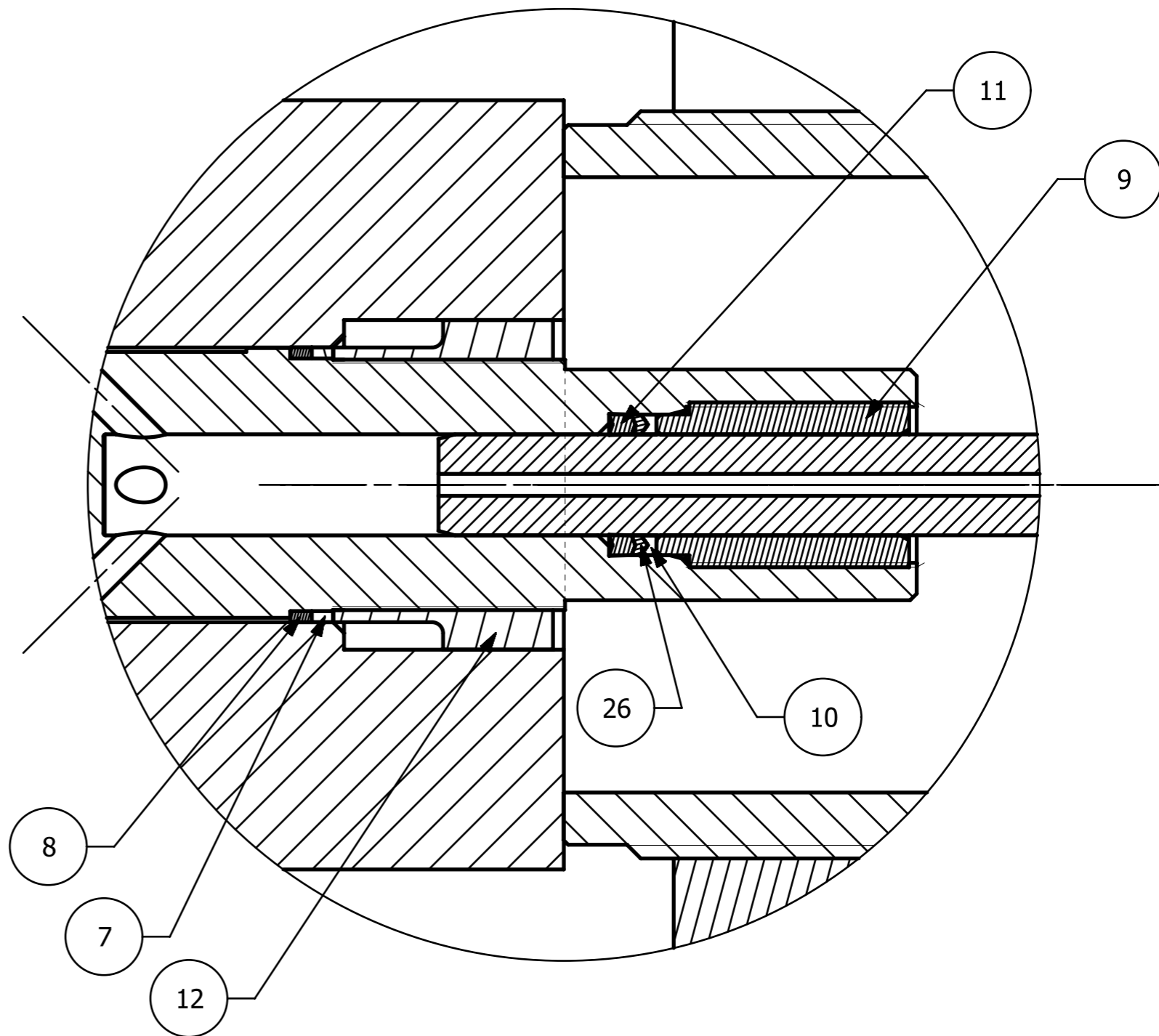

DETAIL F
SCALE 2:5

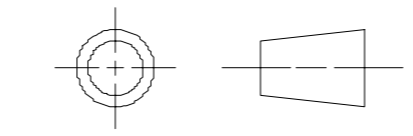

ALL DIMENSIONS IN
MM

FIRST ISSUED		TITLE		
DRAWN BY		IMPULSE PRESSURE GENERATOR Dwg		
CHECKED BY				
APPROVED BY		SIZE	DWG NO.	SHEET REV
		A3		A
		SCALE 1:1		SHEET 2 OF 4

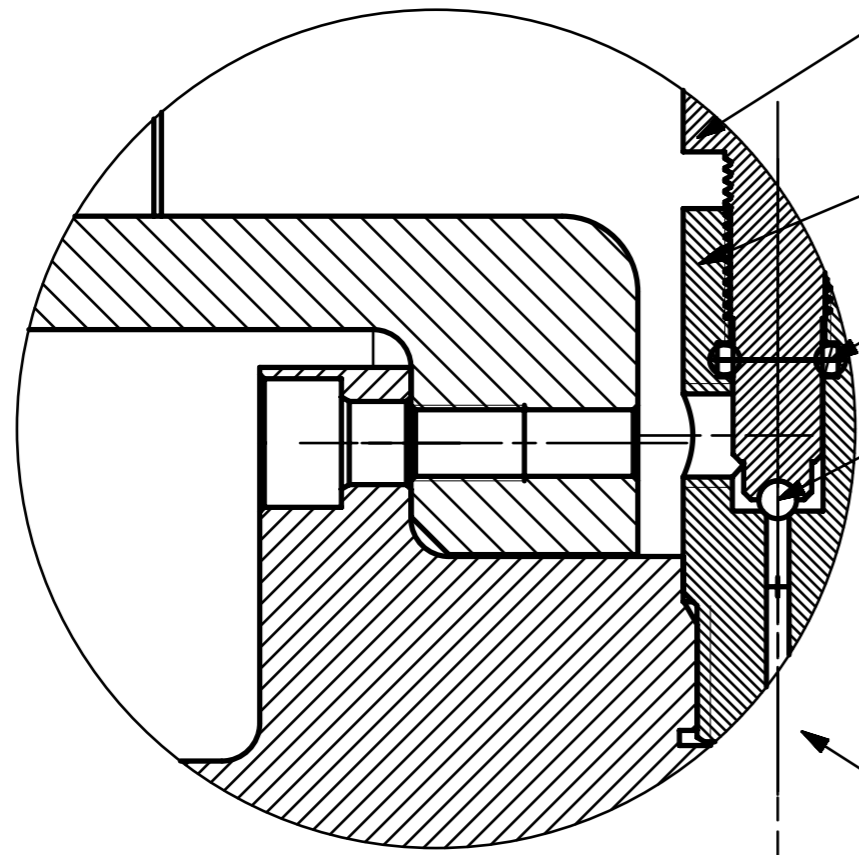

DETAIL H
SCALE 1:1

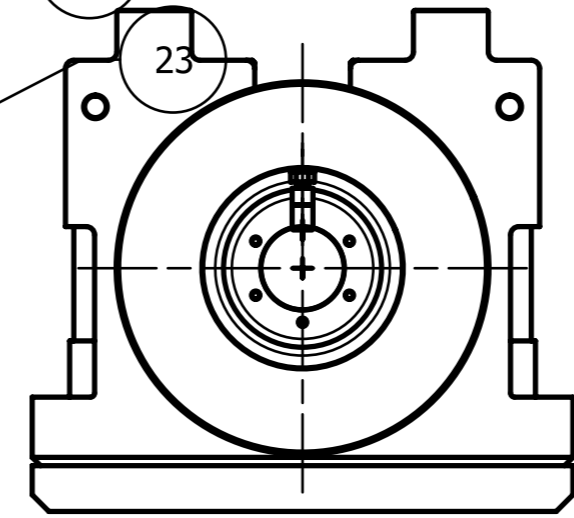

VIEW "A"

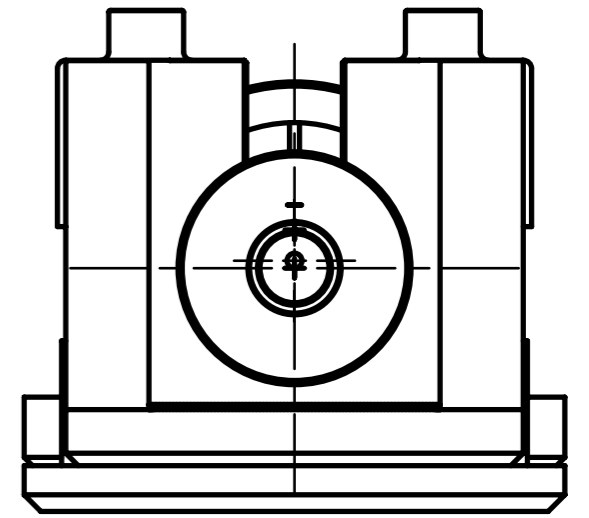

VIEW "B"

ALL DIMENSIONS IN
MM

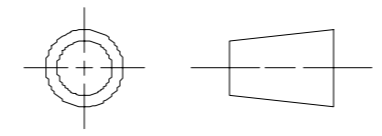

		I.I.T KANPUR		
FIRST ISSUED		I.P.G ASSEMBLY		
DRAWN BY				
CHECKED BY				
APPROVED BY		SIZE	DWG NO.	SHEET REV
		A3	IMPULSE PRESSURE GENERATOR Dwg	A
		SCALE 1:1	SHEET 3 OF 4	

A3

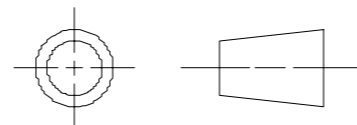
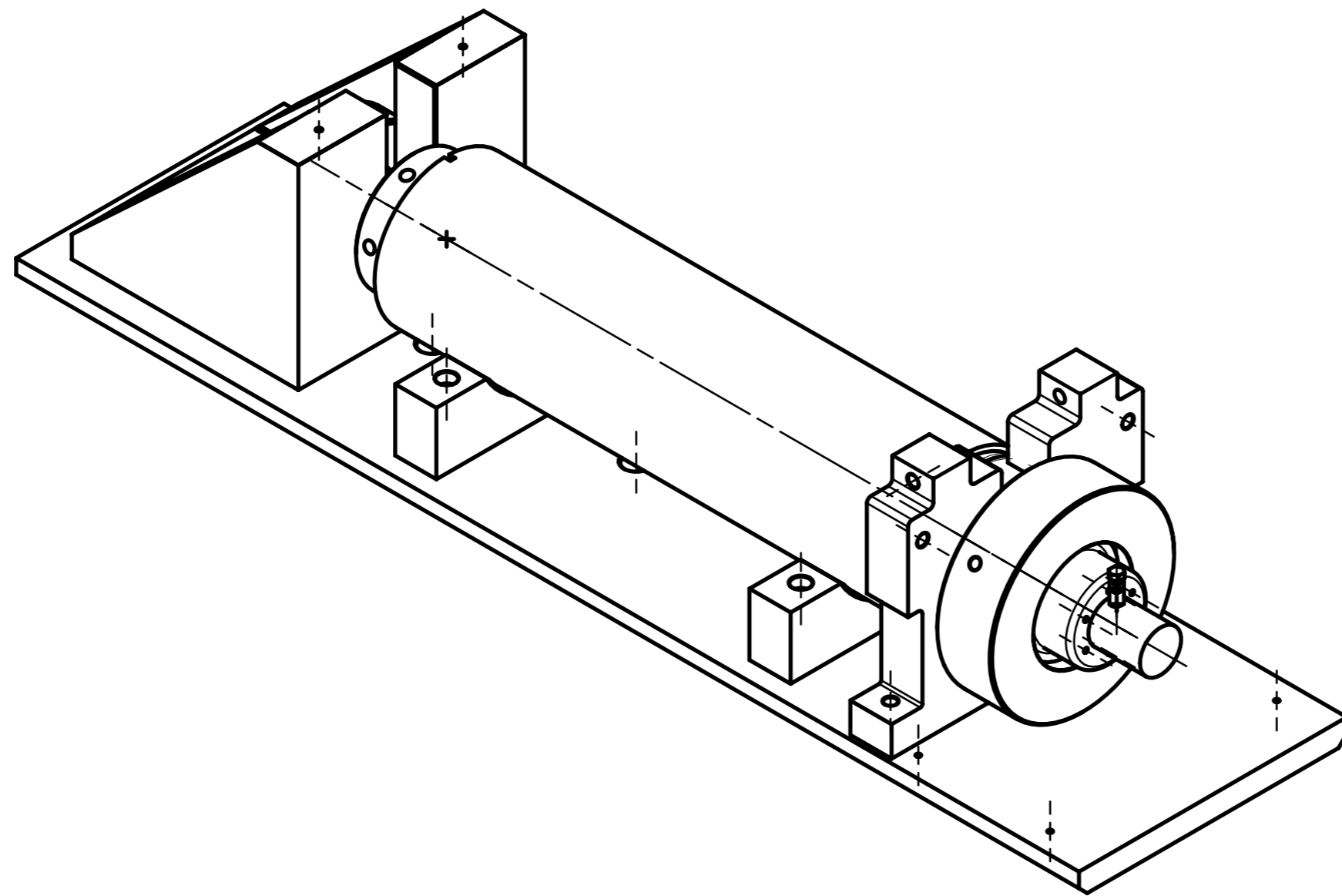

ALL DIMENSIONS IN
MM

		I.I.T KANPUR		
FIRST ISSUED		I.P.G ASSEMBLY		
DRAWN BY				
CHECKED BY		SIZE	DWG NO.	SHEET REV
APPROVED BY		A3	IMPULSE PRESSURE GENERATOR Dwg	A
		SCALE 1:1	SHEET 4 OF 4	

1

2

3

4

5

6

7

8

A

B

C

D

E

F

A

B

C

D

E

F

1

2

3

4

5

6

7

8

A3

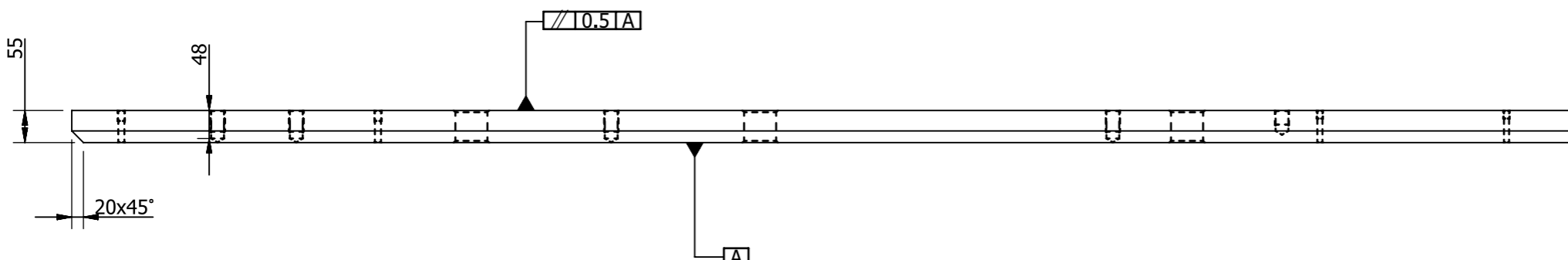
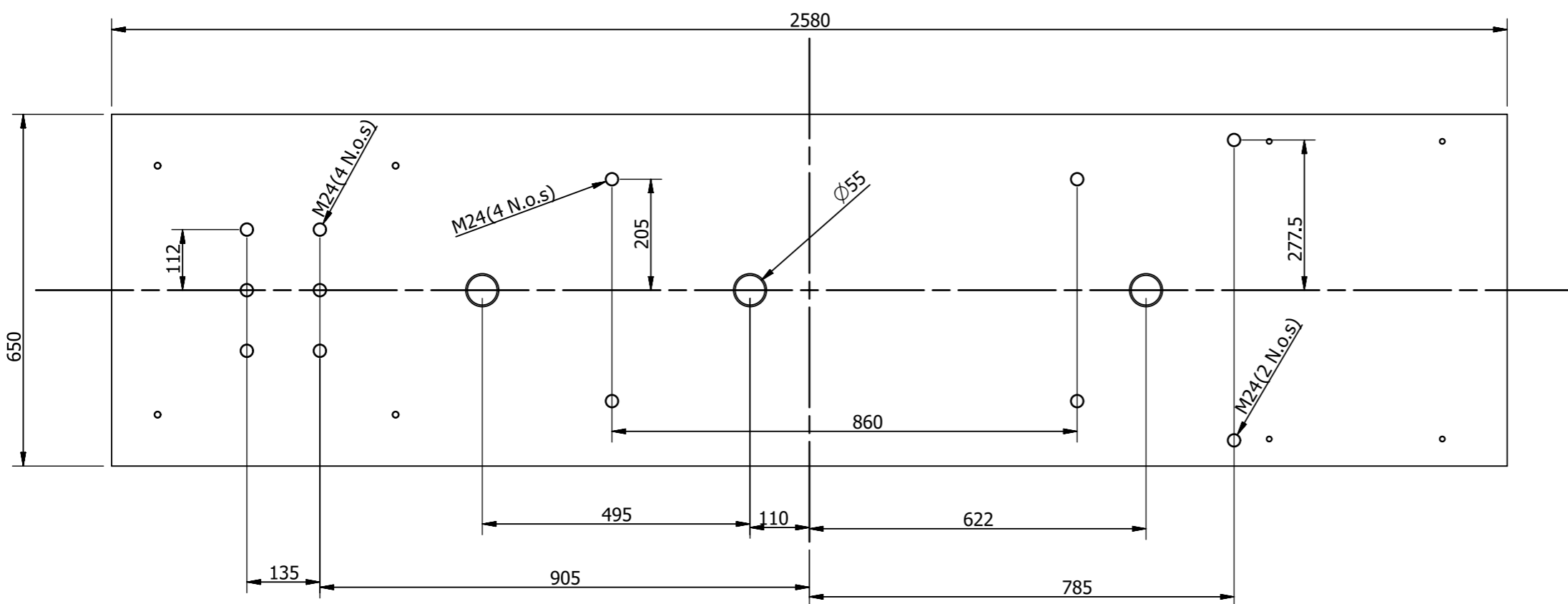

NOTE-1-All Dimension are in mm
 2- Remove all sharp corners
 3-*All Holes are M24x2 Through except specified
 4-*All Hole Position Tolerance +/- 0.3 Unless Specified

Permissible deviations for linear dimensions except for broken edges									
Tolerance class		0.5 upto 3	over 3 upto 6	over 6 upto 30	over 30 upto 120	over 120 upto 400	over 400 upto 1000	over 1000 upto 2000	over 2000 upto 4000
Designation	Description								
m	medium	±0.1	±0.1	±0.2	±0.3	±0.5	±0.8	±1.2	±2

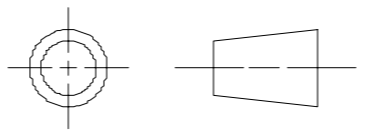

MATERIAL		I.I.T KANPUR		
M.S				
FIRST ISSUED		TITLE		
DRAWN BY		BASE PLATE (PART NO-1)		
CHECKED BY				
APPROVED BY		SIZE	DWG NO.	SHEET REV
		A3	Base Plate N 2020 Drawing	A
		SCALE 1:1	SHEET 1 OF 1	

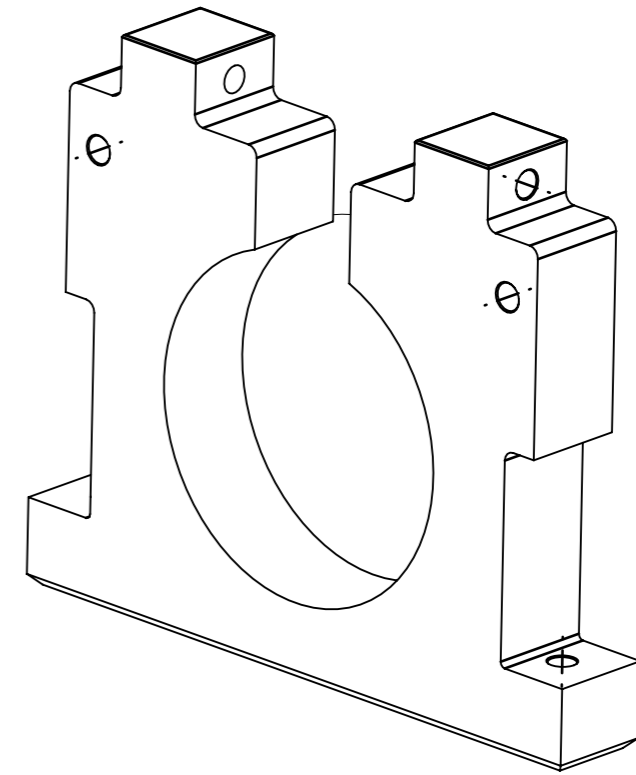
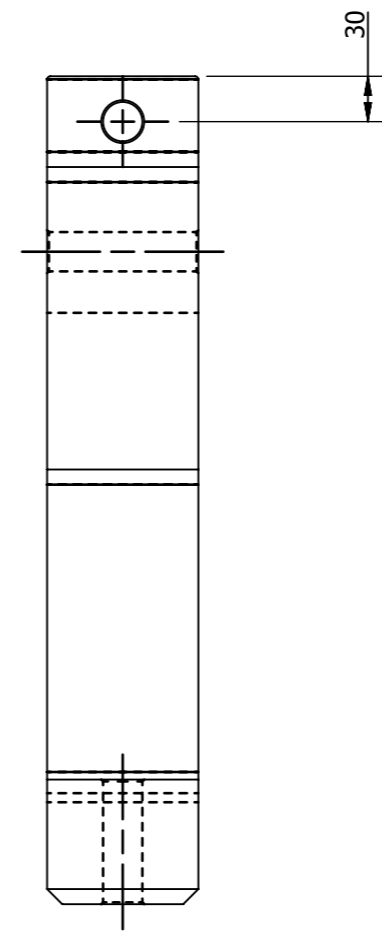
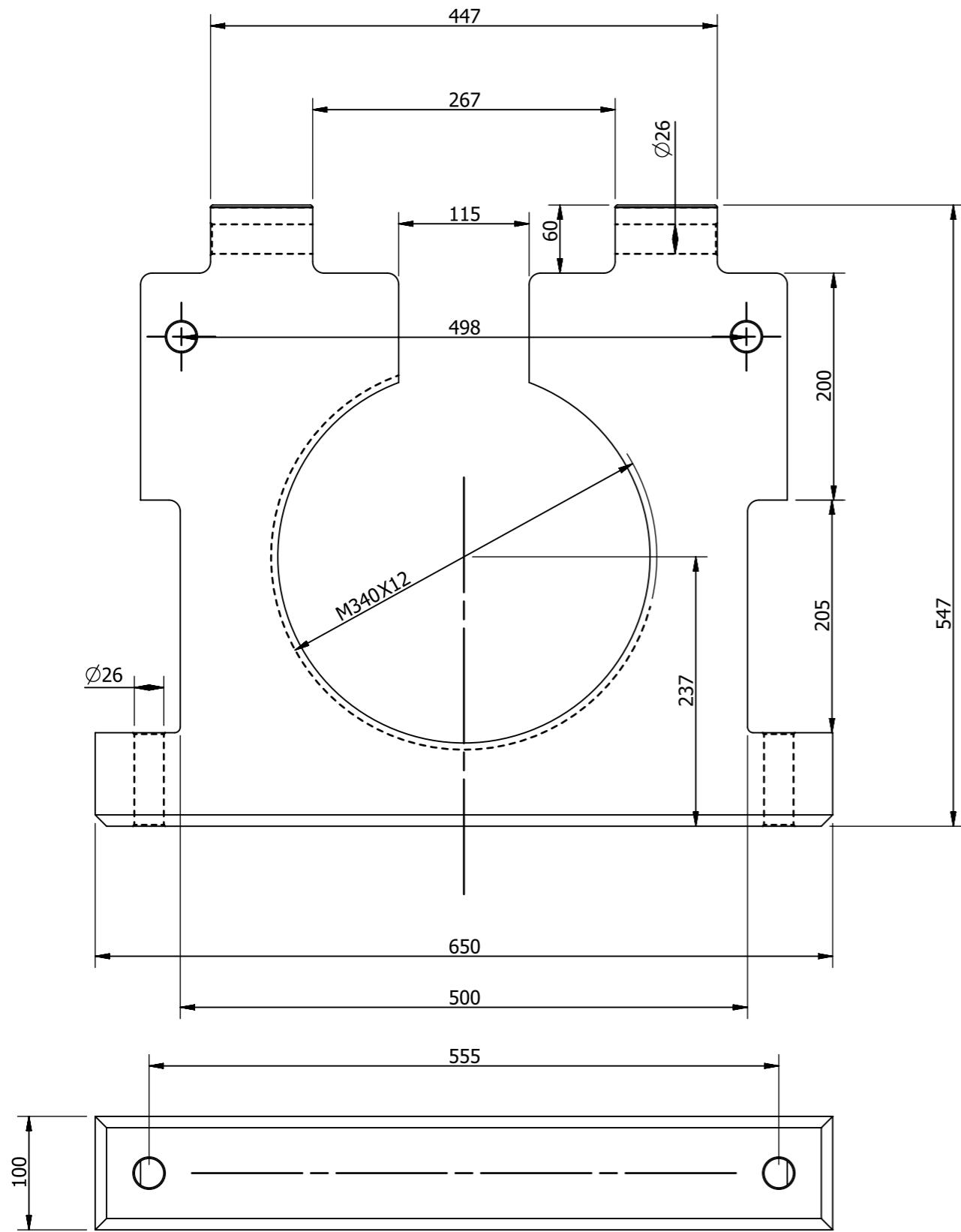

Permissible deviations for linear dimensions except for broken edges									
Tolerance class		0.5 upto 3	over 3 upto 6	over 6 upto 30	over 30 upto 120	over 120 upto 400	over 400 upto 1000	over 1000 upto 2000	over 2000 upto 4000
Designation	Description								
m	medium	±0.1	±0.1	±0.2	±0.3	±0.5	±0.8	±1.2	±2

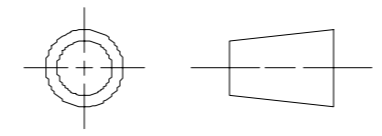

MATERIAL		I.I.T KANPUR		
M.S				
FIRST ISSUED		TITLE		
DRAWN BY		NUT FRONT PUSH (PART NO-2)		
CHECKED BY				
APPROVED BY		SIZE	DWG NO.	SHEET REV
		A3	Nut Front Push_N_2021-dwg	A
				SHEET 1 OF 1

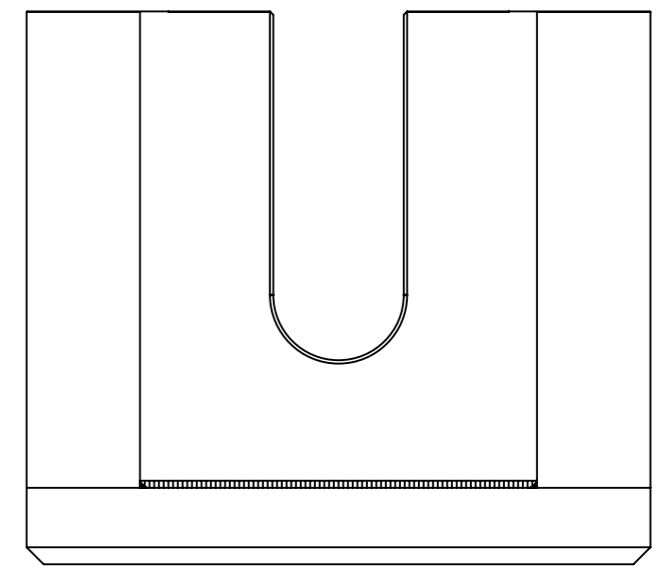
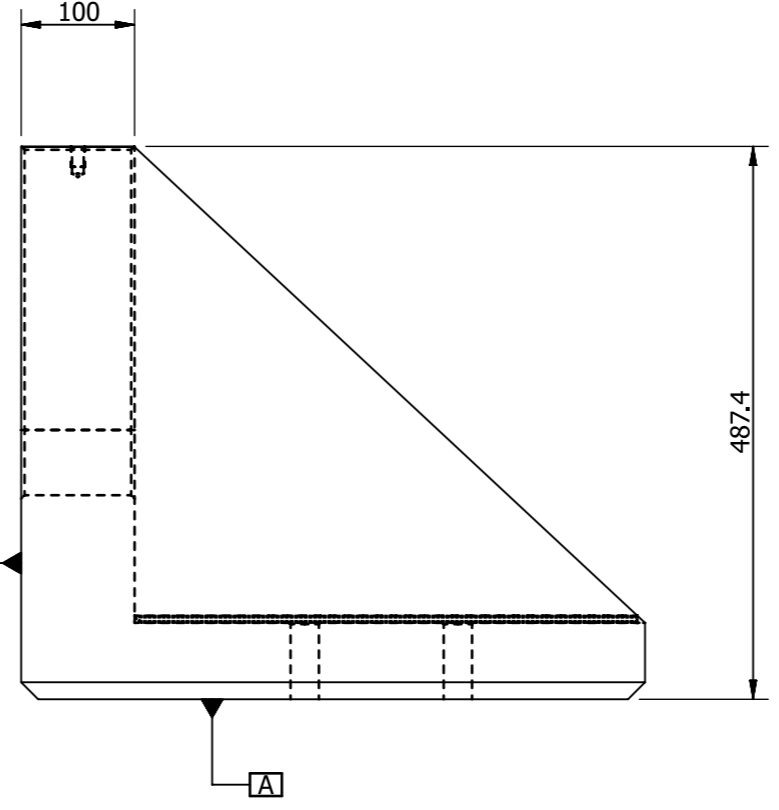
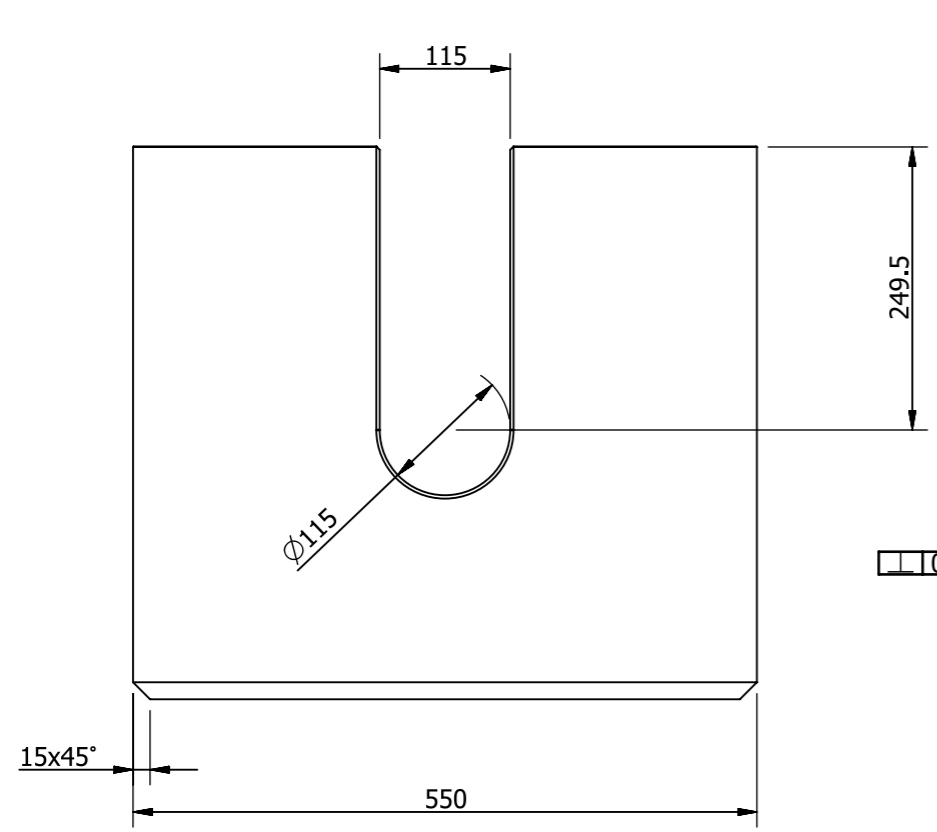
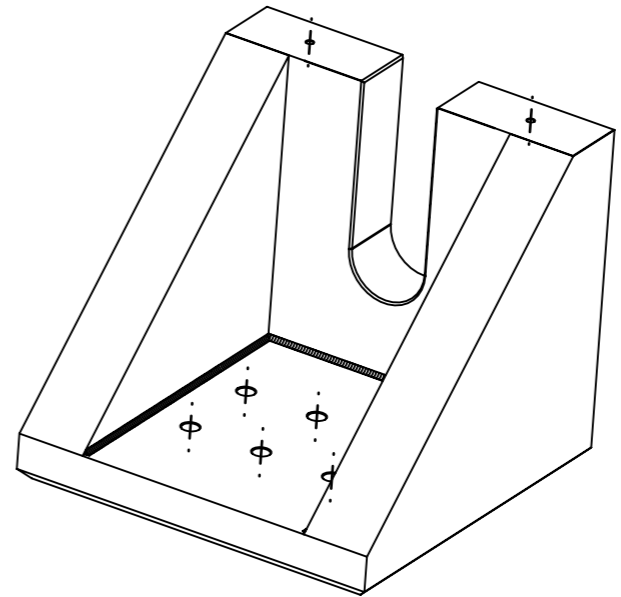
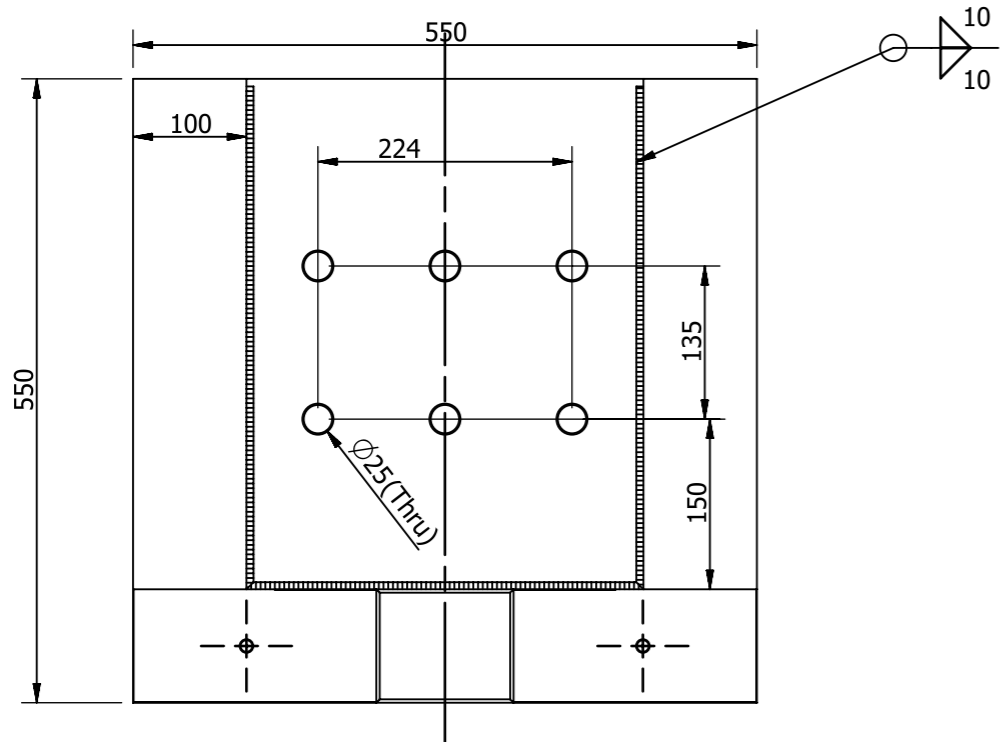

NOTE-All Dimension are in mm
Remove all sharp corners

Permissible deviations for linear dimensions except for broken edges									
Tolerance class		0.5 upto 3	over 3 upto 6	over 6 upto 30	over 30 upto 120	over 120 upto 400	over 400 upto 1000	over 1000 upto 2000	over 2000 upto 4000
Designation	Description								
m	medium	±0.1	±0.1	±0.2	±0.3	±0.5	±0.8	±1.2	±2

MATERIAL M.S		I.I.T KANPUR		
FIRST ISSUED		TITLE		
DRAWN BY		BACK SUPPORT(PART NO-3)		
CHECKED BY				
APPROVED BY		SIZE	DWG NO.	SHEET REV
		A3	Back Support Drawing_N_2020	A
SHEET 1 OF 1				

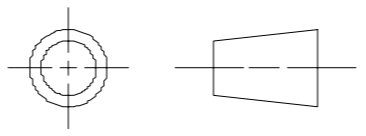

1 2 3 4 5 6 7 8

A B C D E F

A B C D E F

1 2 3 4 5 6 7 8 A3

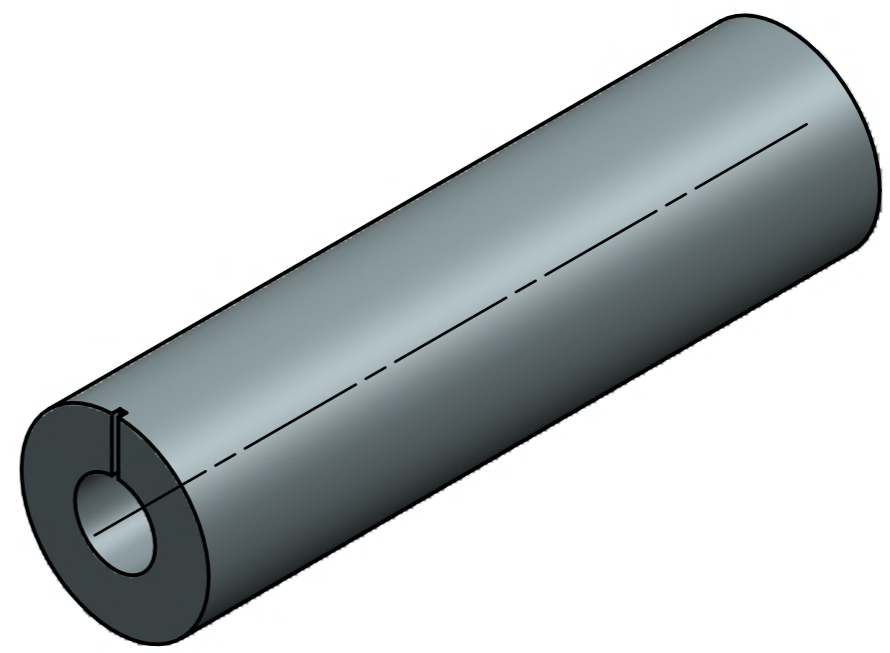
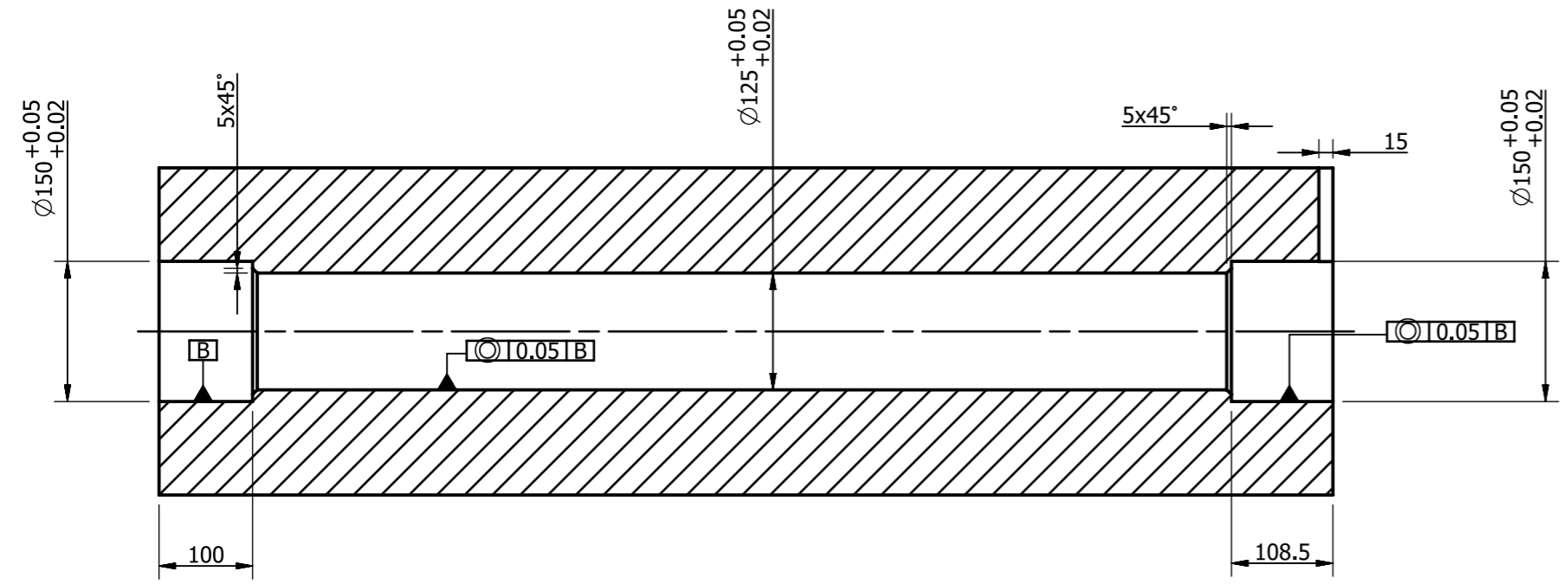
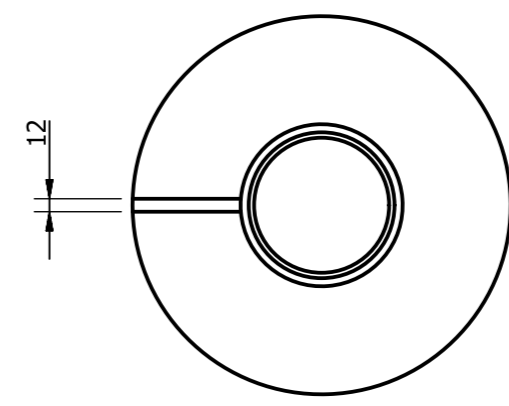
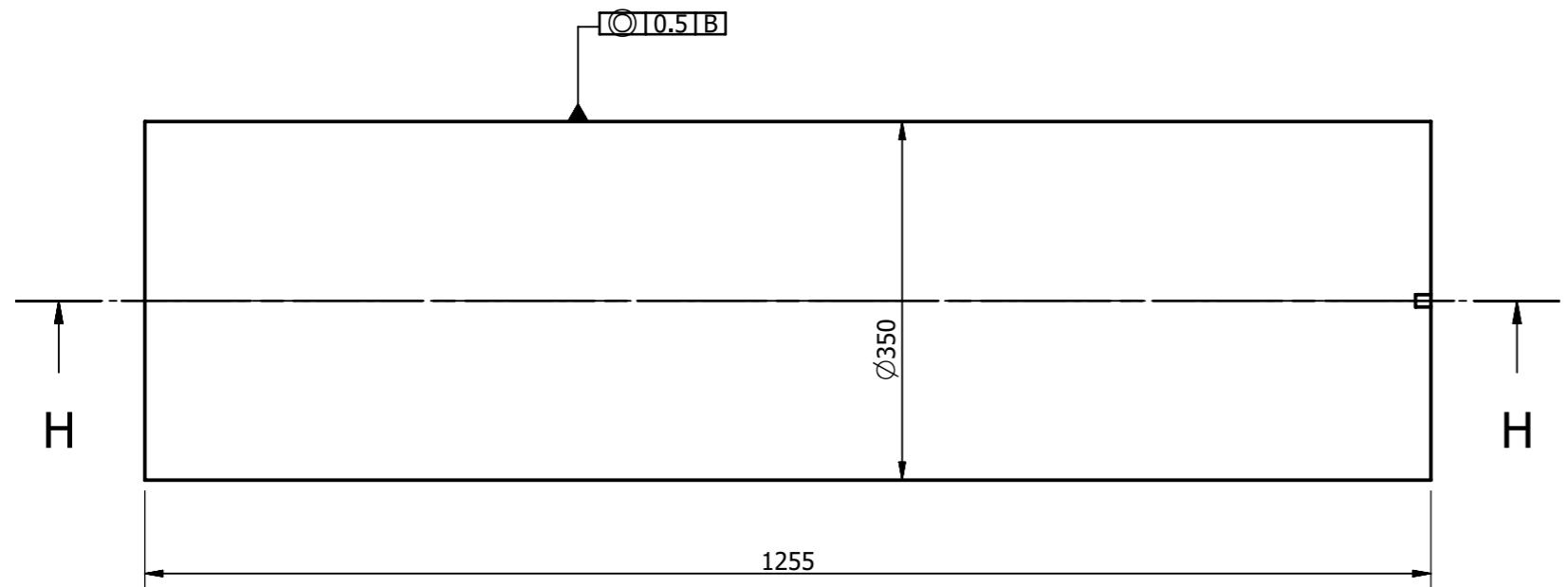

NOTE-All Dimension are in mm
Remove all sharp corners

SECTION H-H

Permissible deviations for linear dimensions except for broken edges									
Tolerance class		0.5 upto 3	over 3 upto 6	over 6 upto 30	over 30 upto 120	over 120 upto 400	over 400 upto 1000	over 1000 upto 2000	over 2000 upto 4000
Designation	Description								
m	medium	±0.1	±0.1	±0.2	±0.3	±0.5	±0.8	±1.2	±2

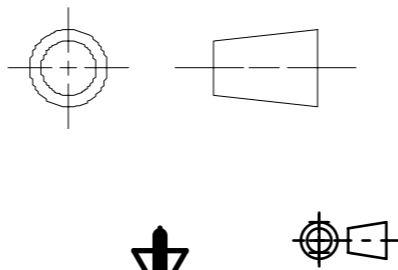

MATERIAL To be provided by customer		I.I.T KANPUR		
FIRST ISSUED		TITLE		
DRAWN BY		Barrel (PART No-4)		
CHECKED BY				
APPROVED BY		SIZE	DWG NO.	SHEET REV
		A3	Barrel Drawing	A
SHEET 1 OF 1				

1 2 3 4 5 6 7 8

A B C D E F

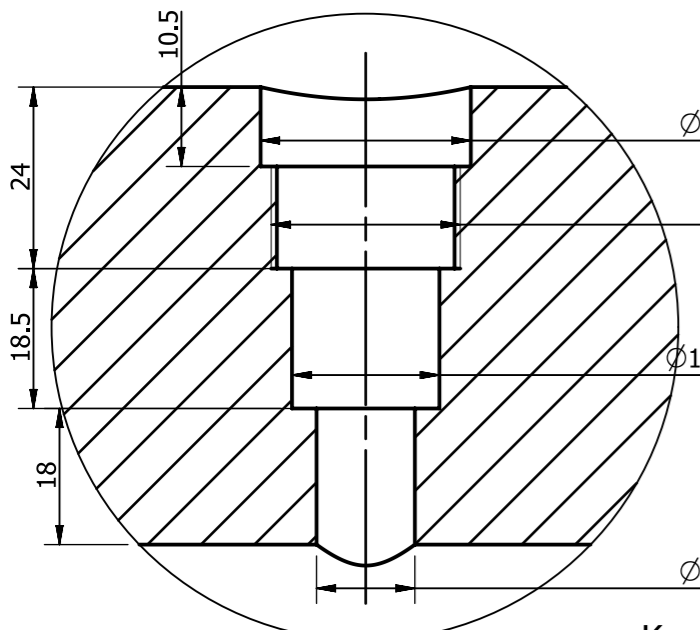
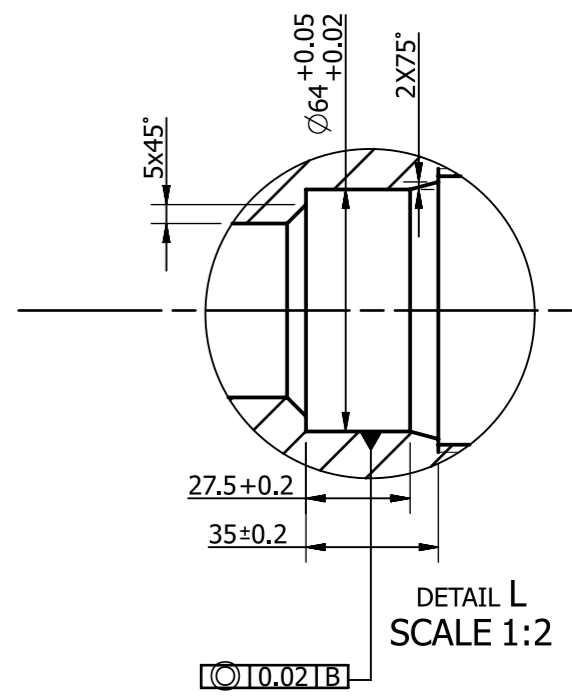
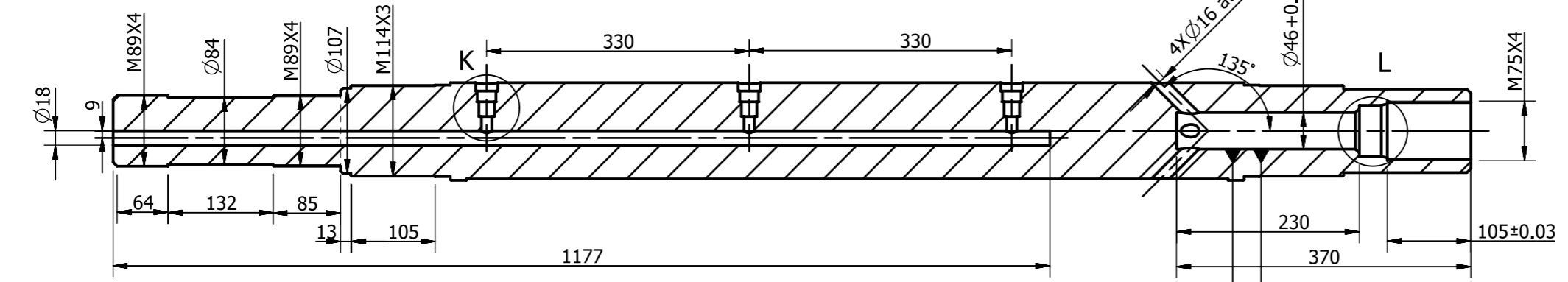
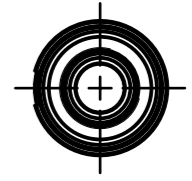
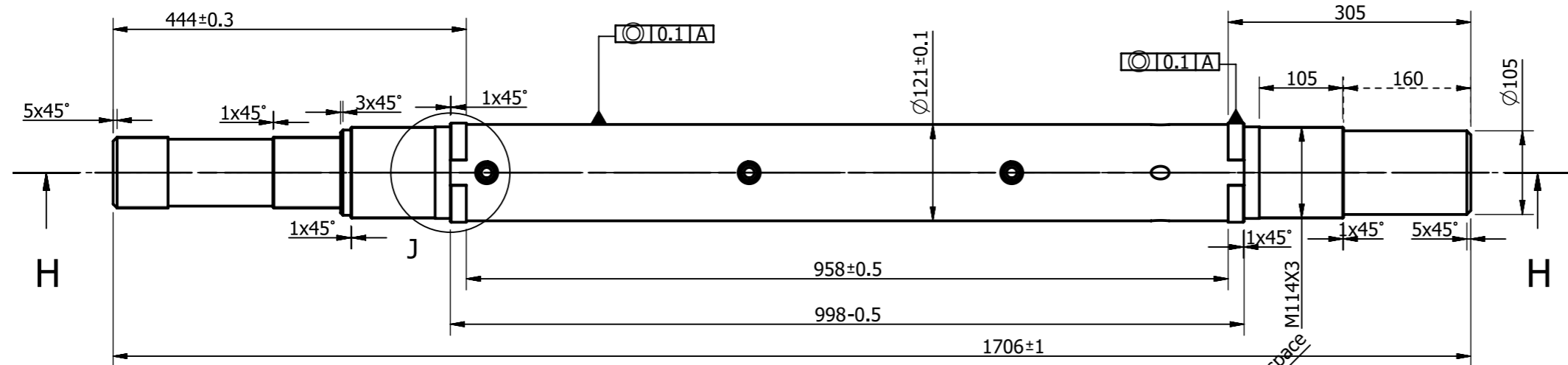

DETAIL K
SCALE 1:1

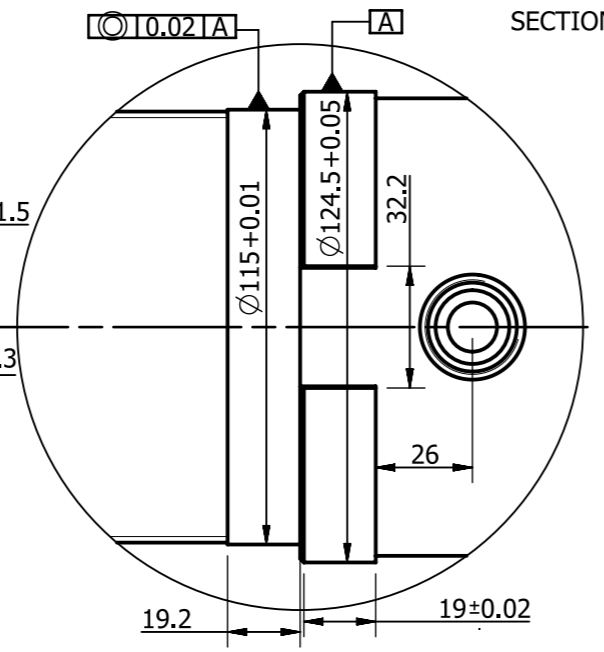

DETAIL J
SCALE 1:2

NOTE-All Dimension are in mm
Remove all sharp corners

Permissible deviations for linear dimensions except for broken edges									
Tolerance class		0.5 upto 3	over 3 upto 6	over 6 upto 30	over 30 upto 120	over 120 upto 400	over 400 upto 1000	over 1000 upto 2000	over 2000 upto 4000
Designation	Description	±0.1	±0.1	±0.2	±0.3	±0.5	±0.8	±1.2	±2
m	medium	±0.1	±0.1	±0.2	±0.3	±0.5	±0.8	±1.2	±2

Material High Strength Steel		I.I.T KANPUR		
FIRST ISSUED		TITLE		
DRAWN BY		Inner Core (part No-5)		
CHECKED BY		SIZE	DWG NO.	SHEET REV
APPROVED BY		A3	Core_N3_2020_Drawing	A
		SHEET 1 OF 2		

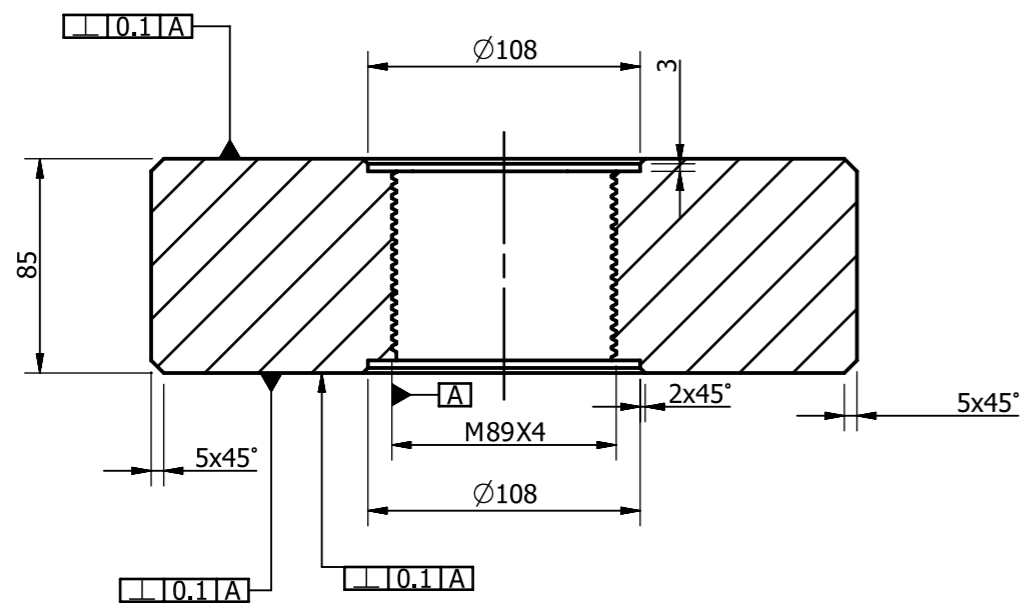
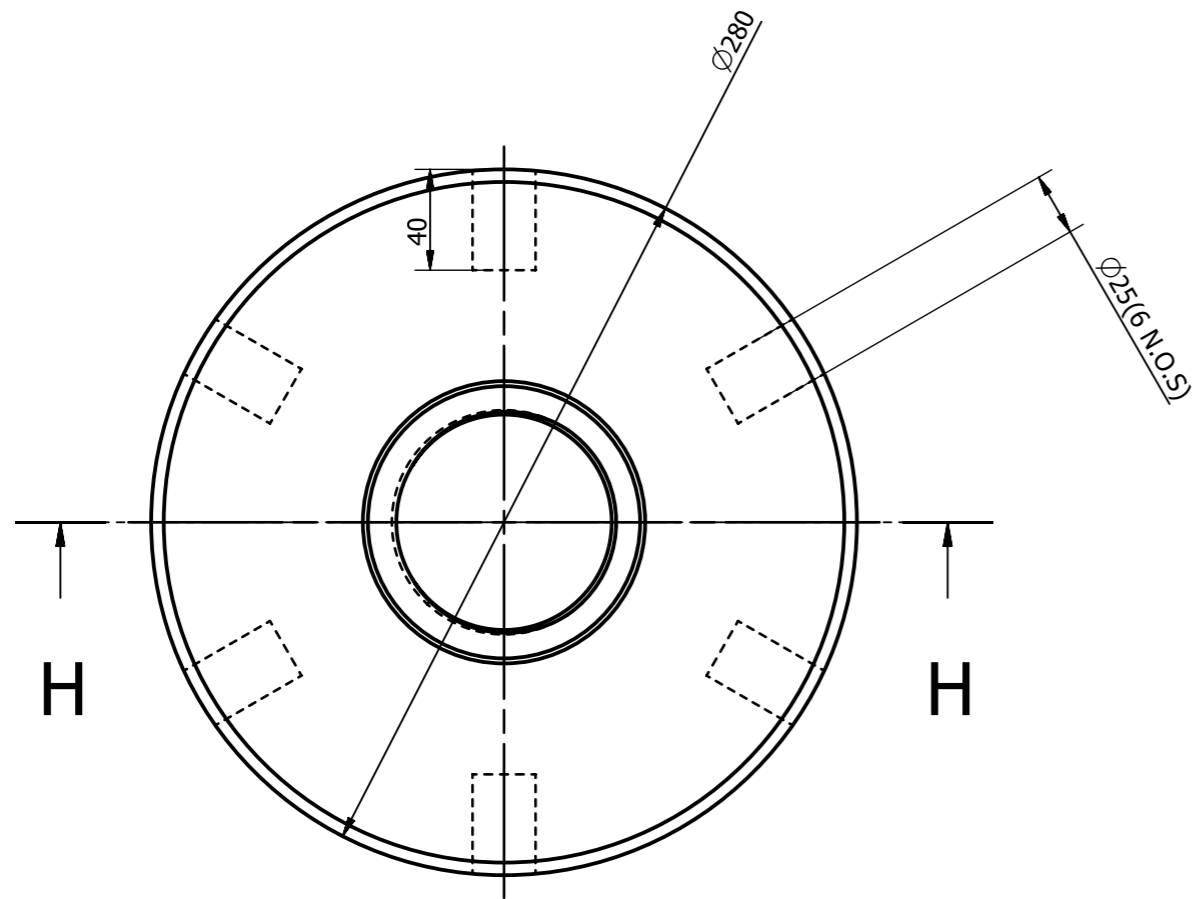

SECTION H-H

MATERIAL MILD STEEL		I.I.T KANPUR		
FIRST ISSUED		TITLE		
DRAWN BY		Back Chuck Nut (PART NO-6)		
CHECKED BY				
APPROVED BY		SIZE	DWG NO.	SHEET REV
		A3	Back Chuck Nut Drawing	A
		SCALE 1:1	SHEET 1 OF 1	

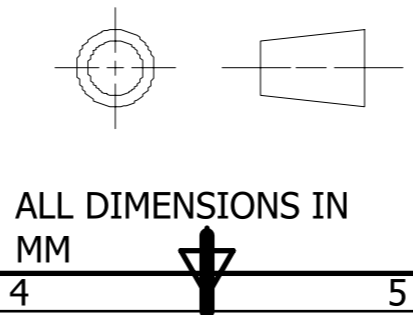

Permissible deviations for linear dimensions except for broken edges									
Tolerance class		0.5 upto 3	over 3 upto 6	over 6 upto 30	over 30 upto 120	over 120 upto 400	over 400 upto 1000	over 1000 upto 2000	over 2000 upto 4000
Designation	Description	±0.1	±0.1	±0.2	±0.3	±0.5	±0.8	±1.2	±2
m	medium								

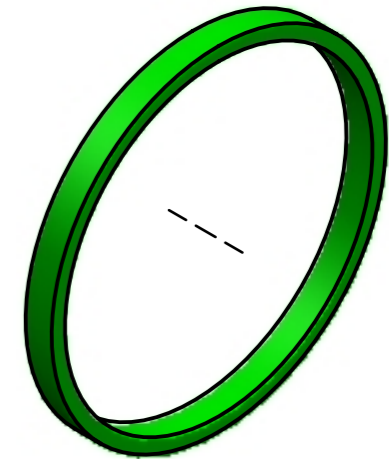
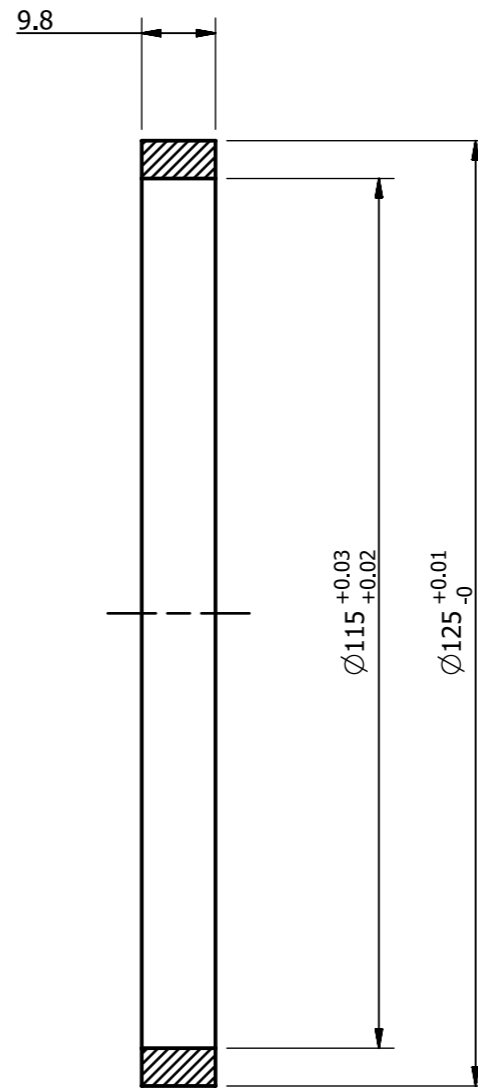
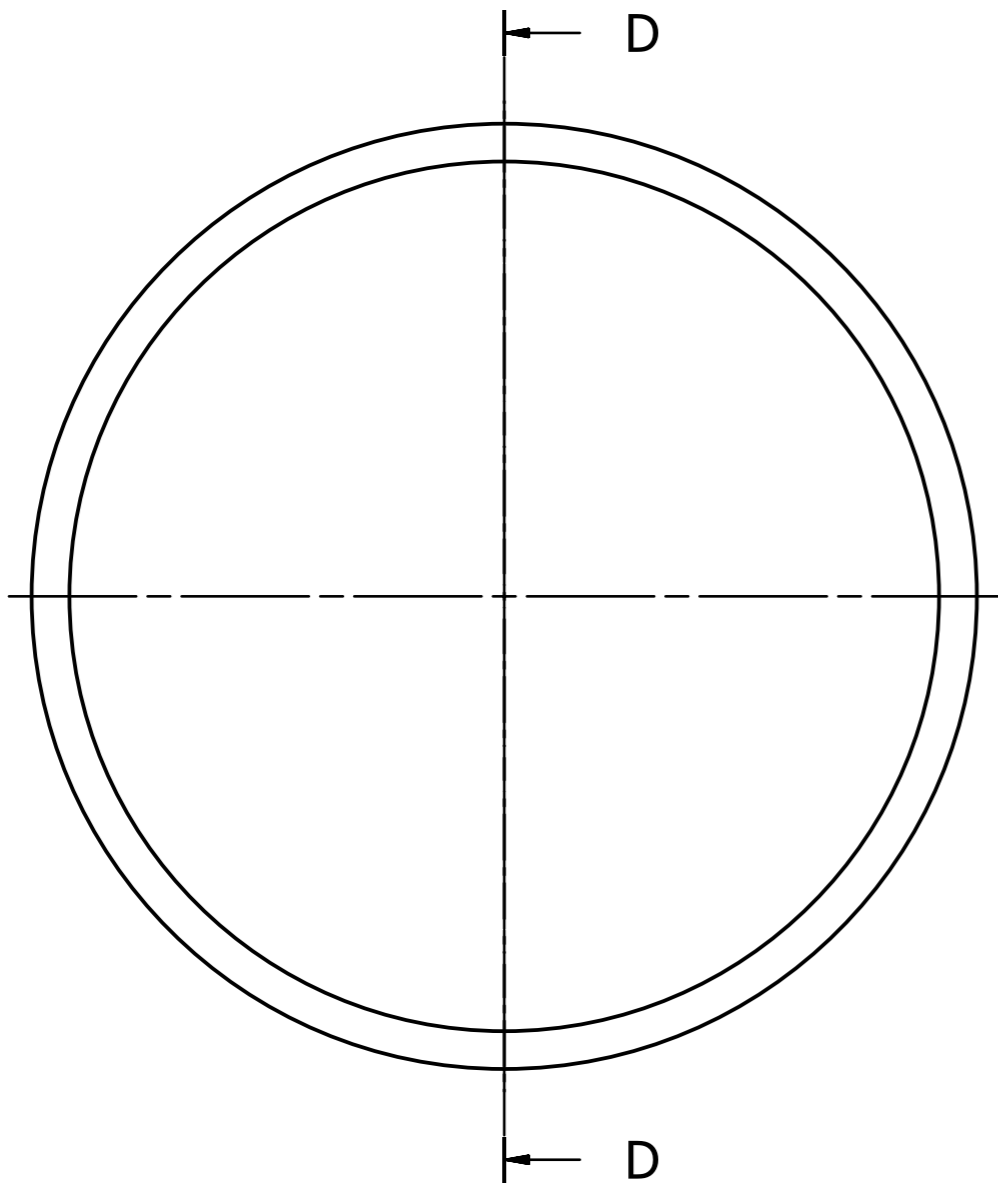

SECTION D-D

REMOVE ALL SHARP CORNERS

Permissible deviations for linear dimensions except for broken edges									
Tolerance class		0.5 upto 3	over 3 upto 6	over 6 upto 30	over 30 upto 120	over 120 upto 400	over 400 upto 1000	over 1000 upto 2000	over 2000 upto 4000
Designation	Description								
m	medium	±0.1	±0.1	±0.2	±0.3	±0.5	±0.8	±1.2	±2

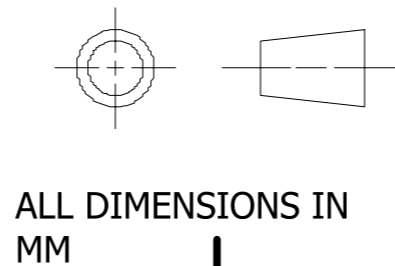

MATERIAL BRASS		I.I.T KANPUR		
FIRST ISSUED		TITLE		
DRAWN BY		Static Brass Seal (Part No-7)		
CHECKED BY				
APPROVED BY		SIZE	DWG NO.	SHEET REV
		A3	Brass Seal FRONT Drawing	A
		SCALE 1:1	SHEET 1 OF 1	

A3

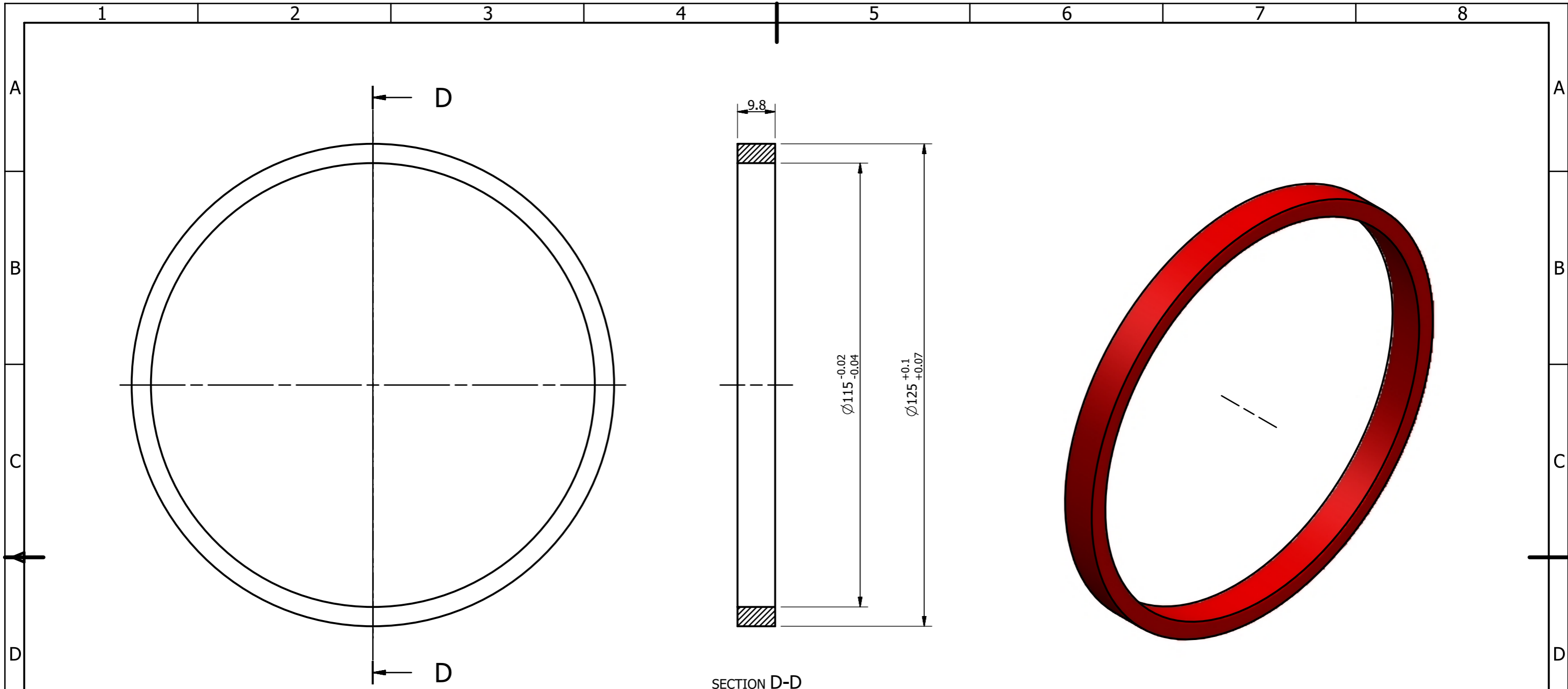

SECTION D-D

NOTE- Remove all sharp corners

Permissible deviations for linear dimensions except for broken edges									
Tolerance class		0.5 upto 3	over 3 upto 6	over 6 upto 30	over 30 upto 120	over 120 upto 400	over 400 upto 1000	over 1000 upto 2000	over 2000 upto 4000
Designation	Description								
m	medium	±0.1	±0.1	±0.2	±0.3	±0.5	±0.8	±1.2	±2

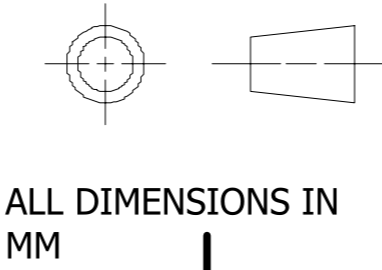

MATERIAL PTFE		I.I.T KANPUR		
FIRST ISSUED		TITLE		
DRAWN BY		Static P.T.F.E Seal (Part No-8)		
CHECKED BY				
APPROVED BY		SIZE	DWG NO.	SHEET REV
		A3	PTFE FRONT Drawing	A
		SCALE 1:1	SHEET 1 OF 1	

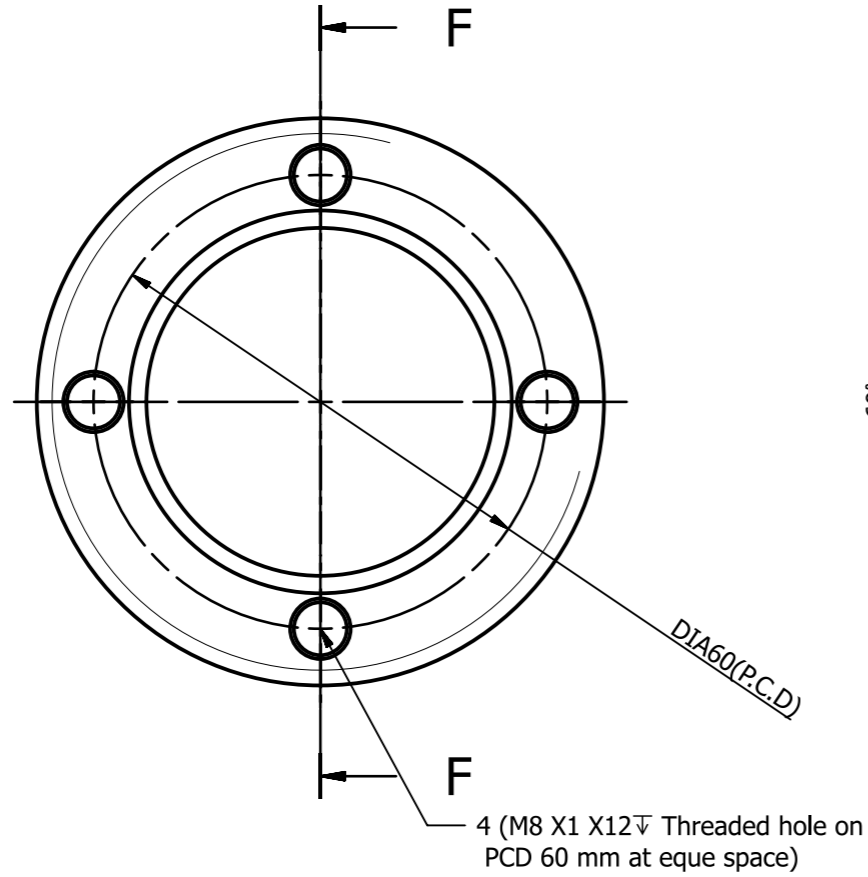

SCALE 1:1

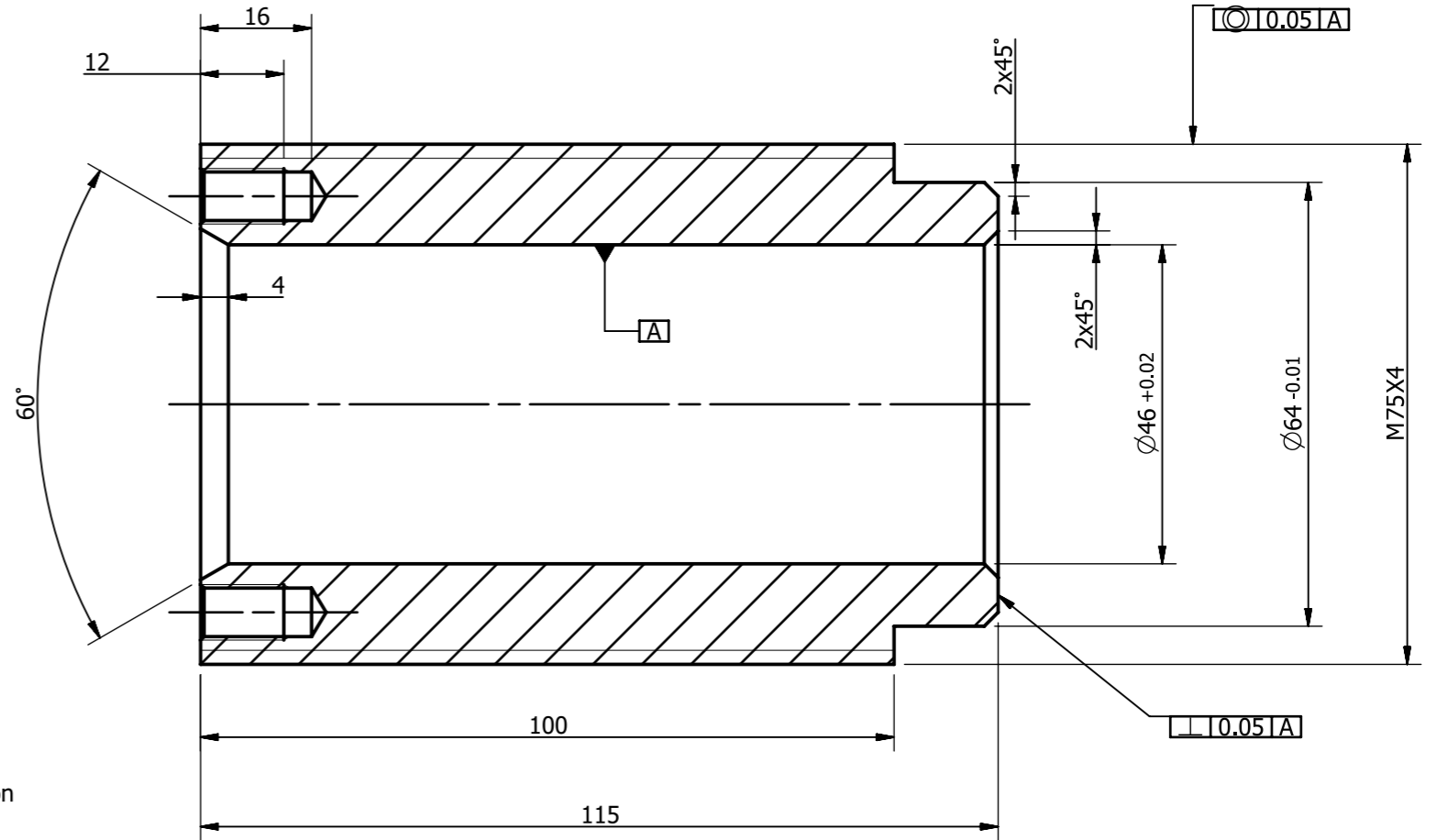

SECTION F-F

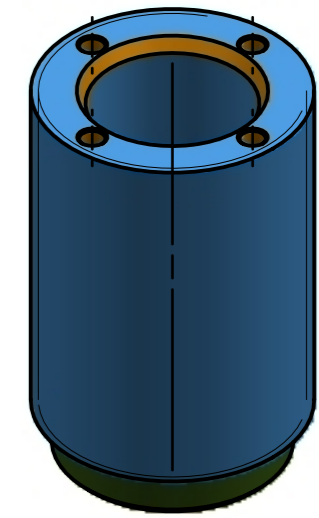

Permissible deviations for linear dimensions except for broken edges									
Tolerance class		0.5 upto 3	over 3 upto 6	over 6 upto 30	over 30 upto 120	over 120 upto 400	over 400 upto 1000	over 1000 upto 2000	over 2000 upto 4000
Designation	Description								
m	medium	±0.1	±0.1	±0.2	±0.3	±0.5	±0.8	±1.2	±2

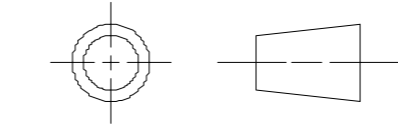

ALL DIMENSIONS IN MM

MATERIAL EN-24 "T" Condition		I.I.T KANPUR			
FIRST ISSUED		TITLE			
DRAWN BY		Dynamic Seal Guide (Part No-9)			
CHECKED BY		SIZE	DWG NO.	SHEET REV	
APPROVED BY		A3	High Pressure Seal Guide Dynamic Drawing	A	
		SCALE 1:1	SHEET 1 OF 1		

A3

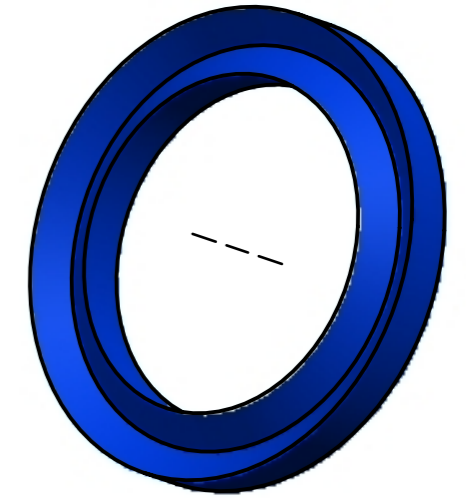
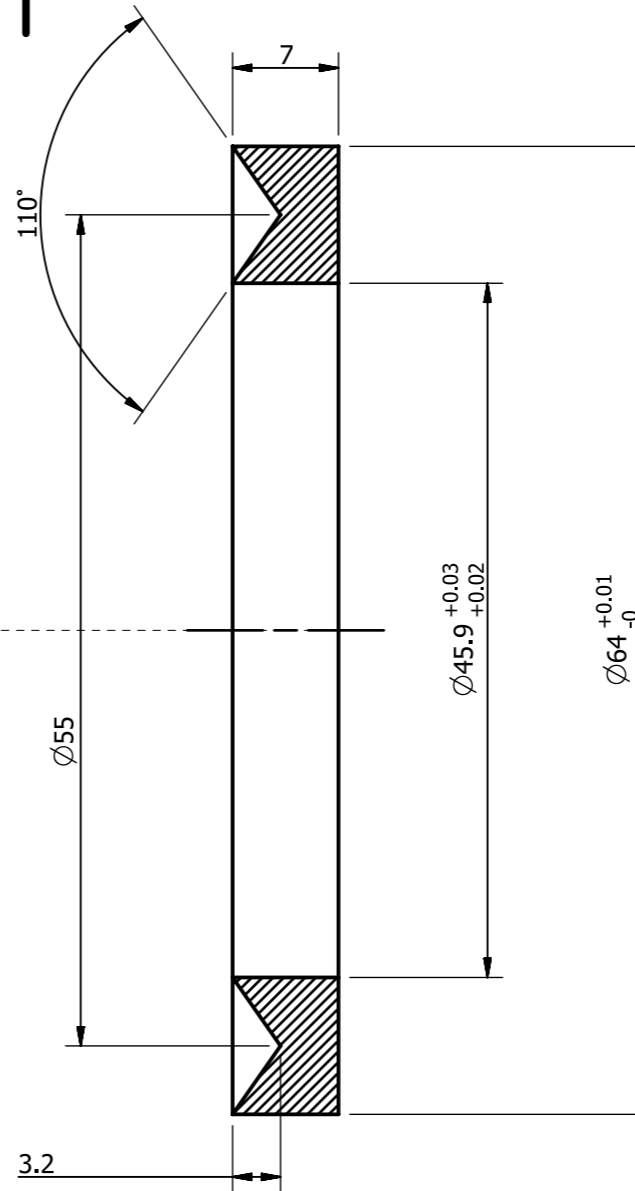
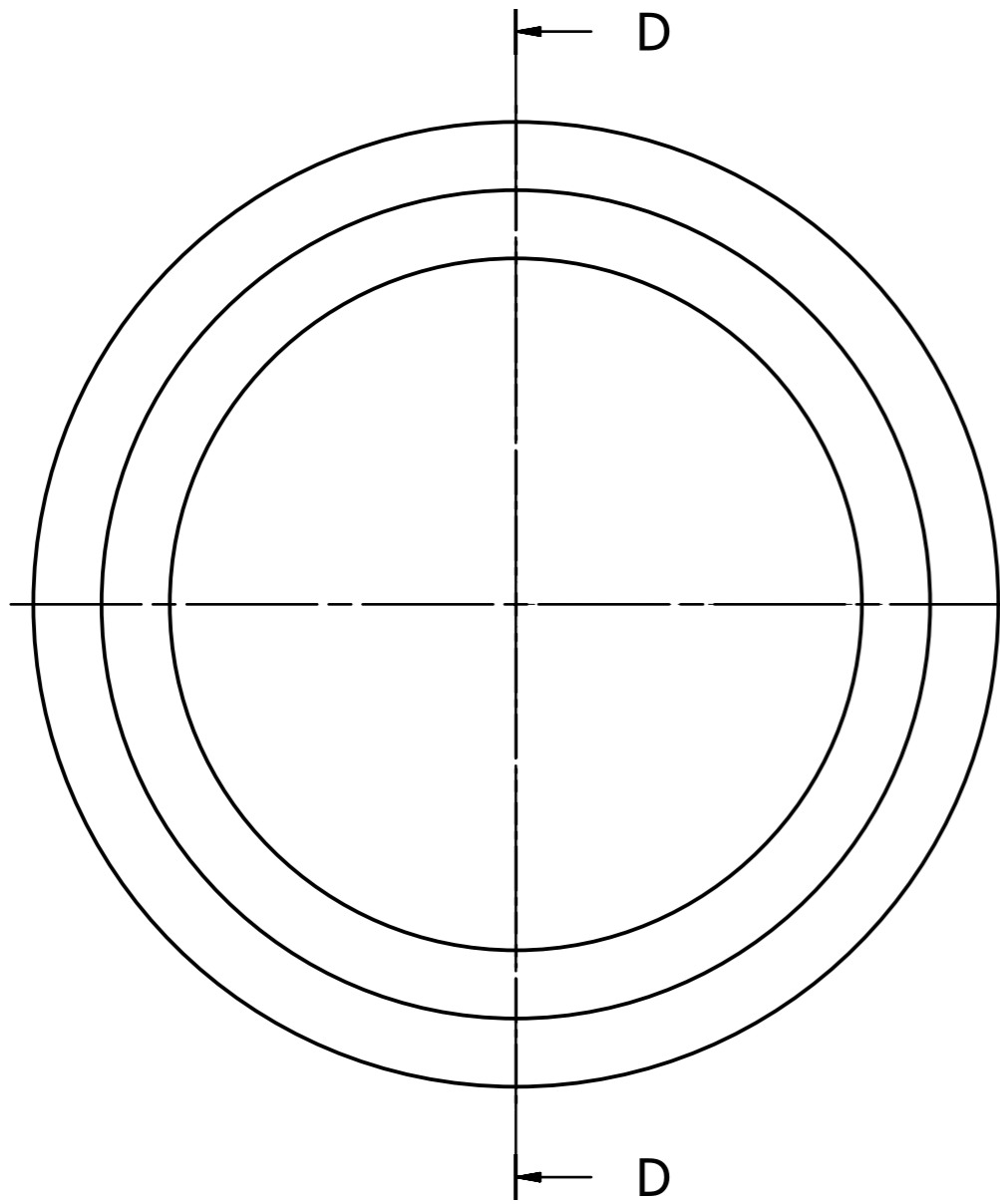

SECTION D-D

NOTE- Remove all sharp corners

Permissible deviations for linear dimensions except for broken edges									
Tolerance class		0.5 upto 3	over 3 upto 6	over 6 upto 30	over 30 upto 120	over 120 upto 400	over 400 upto 1000	over 1000 upto 2000	over 2000 upto 4000
Designation	Description								
m	medium	±0.1	±0.1	±0.2	±0.3	±0.5	±0.8	±1.2	±2

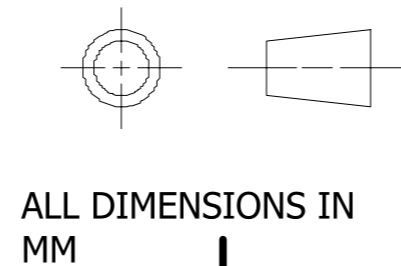

MATERIAL Stain Less Steel		I.I.T KANPUR		
FIRST ISSUED		TITLE		
DRAWN BY		Dynamic S.S seal (Part No-10)		
CHECKED BY		SIZE	DWG NO.	SHEET REV
APPROVED BY		A3	SS Seal Dynamic Drawing	A
		SCALE 1:1	SHEET 1 OF 1	

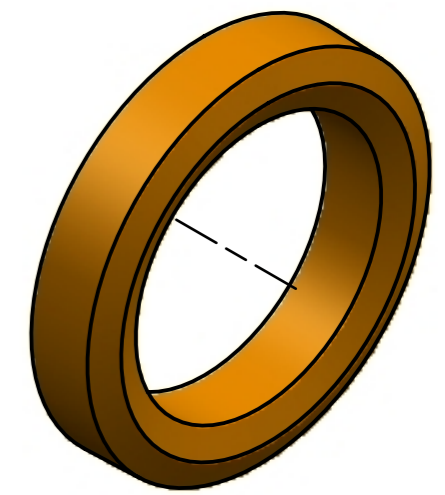
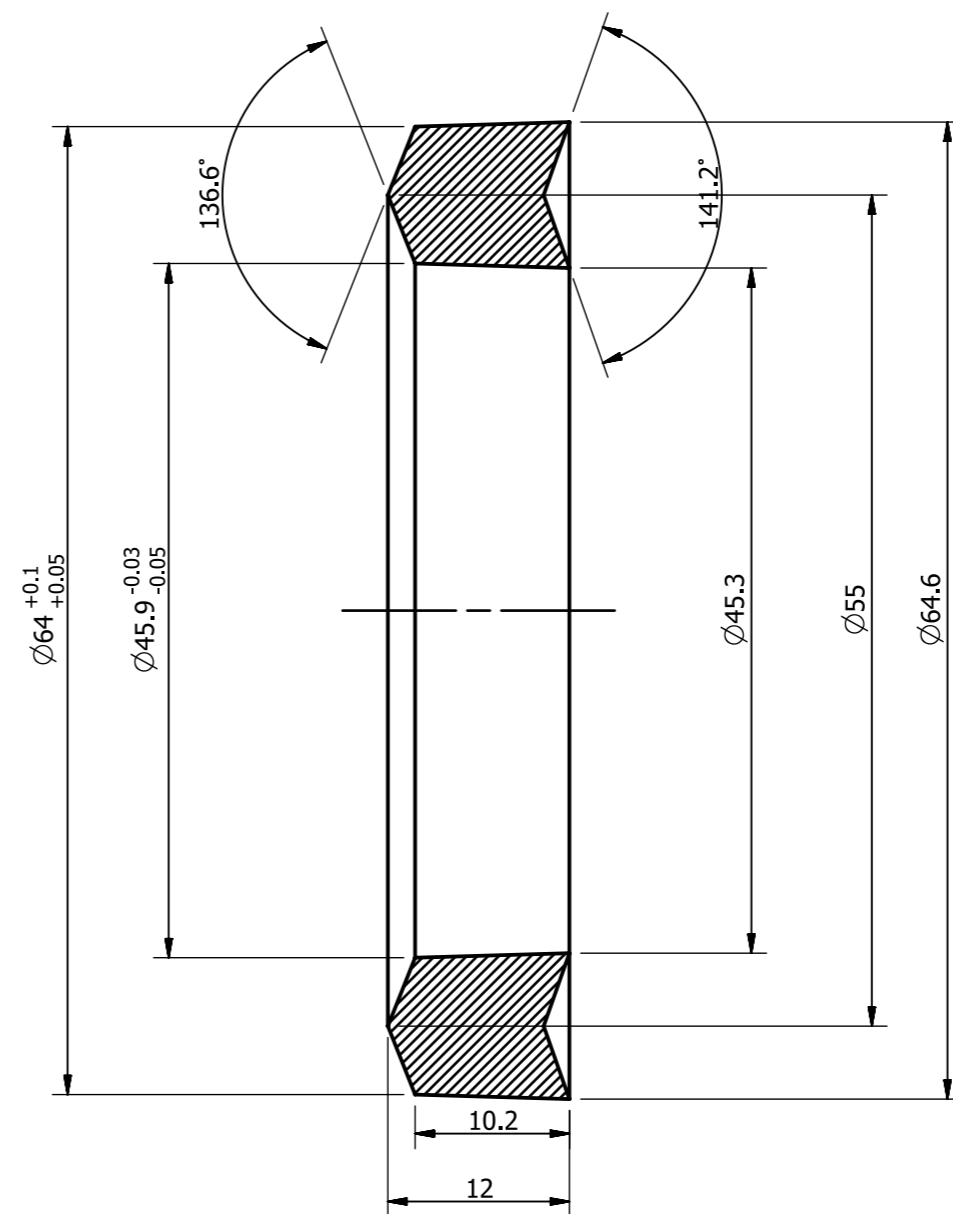
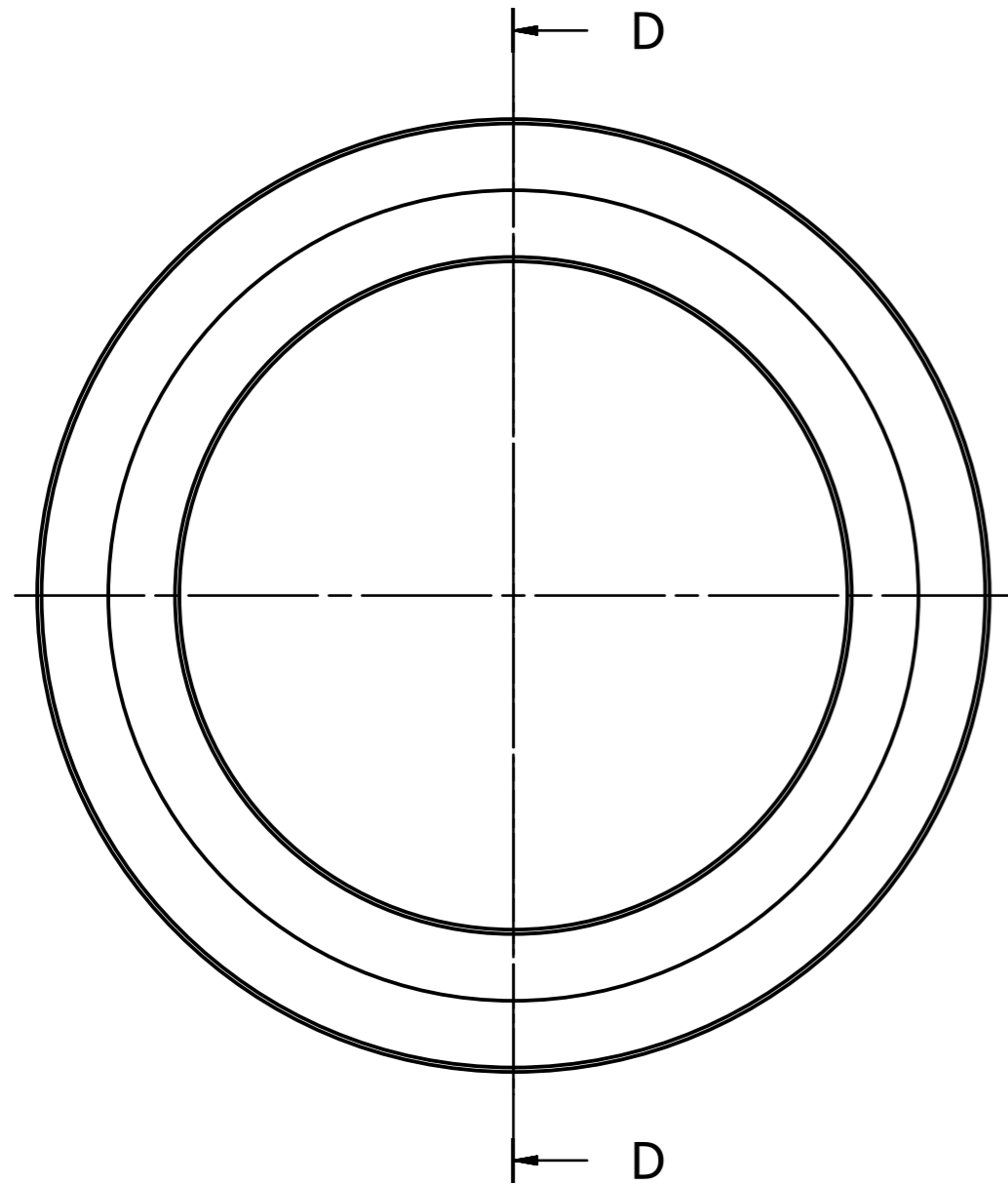

SECTION D-D

NOTE- Remove all sharp corners

Permissible deviations for linear dimensions except for broken edges									
Tolerance class		0.5 upto 3	over 3 upto 6	over 6 upto 30	over 30 upto 120	over 120 upto 400	over 400 upto 1000	over 1000 upto 2000	over 2000 upto 4000
Designation	Description								
m	medium	±0.1	±0.1	±0.2	±0.3	±0.5	±0.8	±1.2	±2

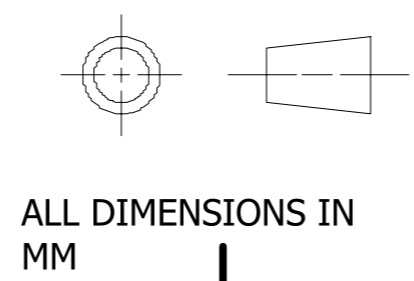

MATERIAL PTFE		I.I.T KANPUR		
FIRST ISSUED		TITLE		
DRAWN BY		Dynamic P.T.F.E seal (Part No-11)		
CHECKED BY		SIZE	DWG NO.	SHEET REV
APPROVED BY		A3	PTFE Dynamic Seal Drawing	A
		SCALE 1:1	SHEET 1 OF 1	

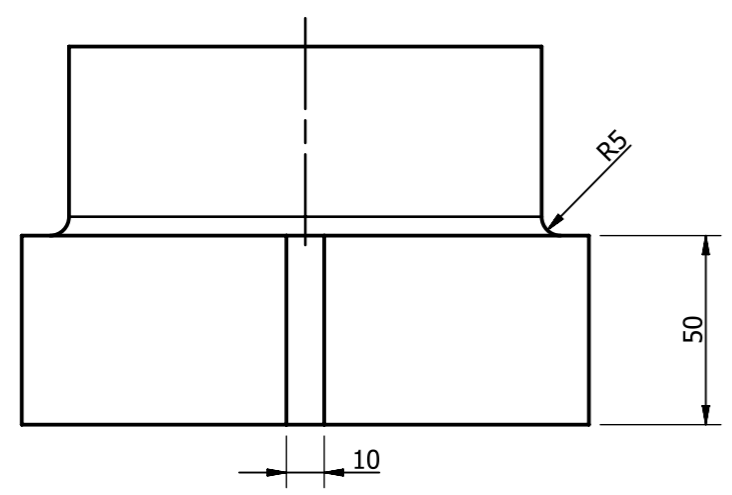

SCALE 1:2

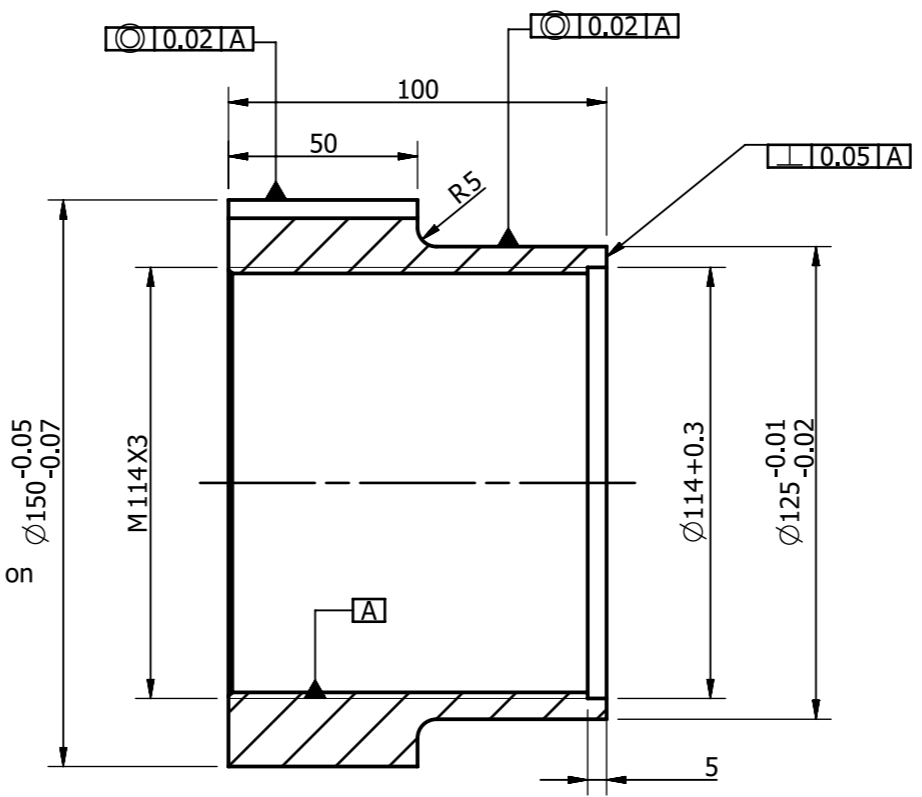
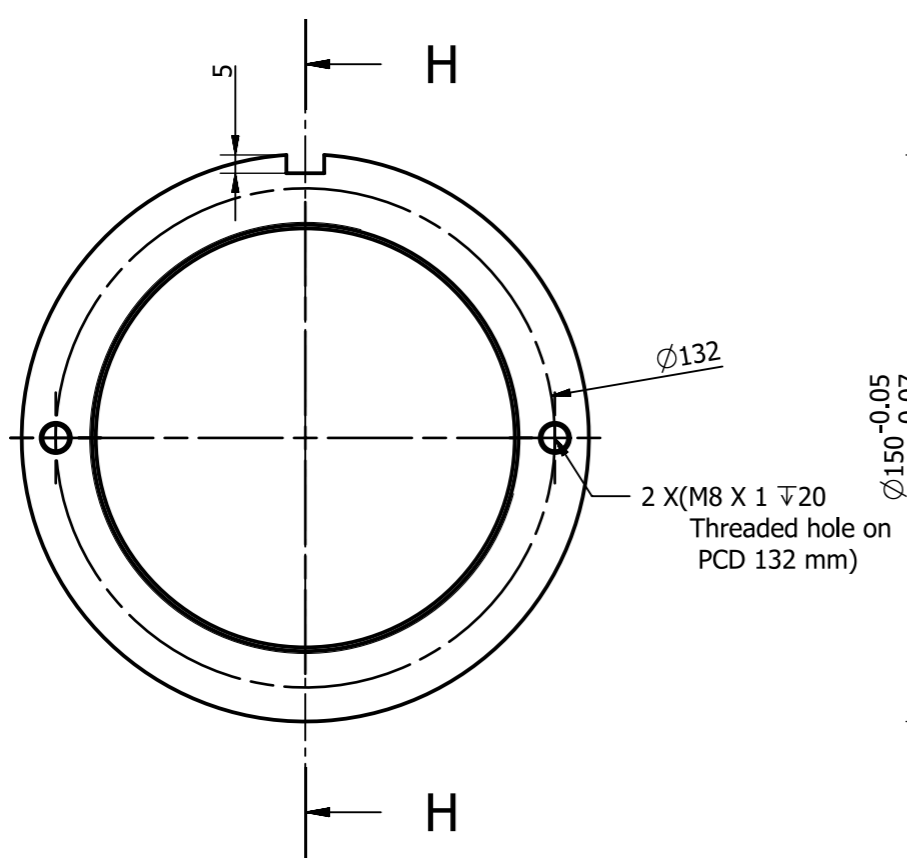
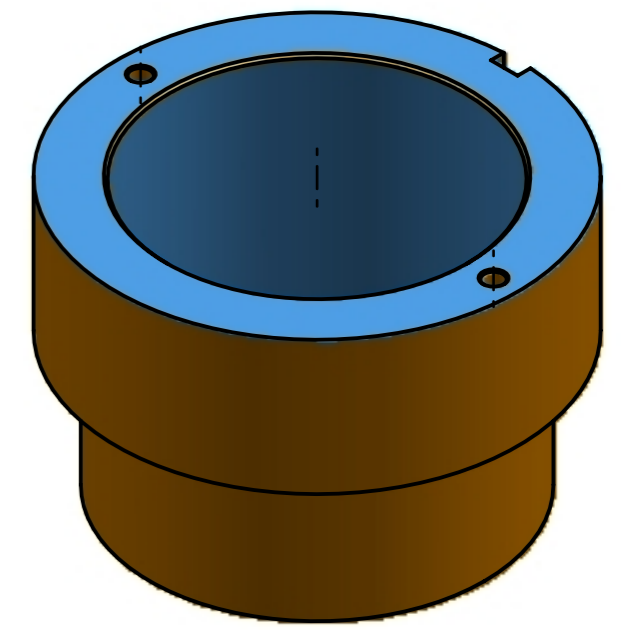

SECTION H-H

Permissible deviations for linear dimensions except for broken edges									
Tolerance class		0.5 upto 3	over 3 upto 6	over 6 upto 30	over 30 upto 120	over 120 upto 400	over 400 upto 1000	over 1000 upto 2000	over 2000 upto 4000
Designation	Description	±0.1	±0.1	±0.2	±0.3	±0.5	±0.8	±1.2	±2
m	medium								

ALL DIMENSIONS IN MM

MATERIAL EN-24" T Condition		I.I.T KANPUR		
FIRST ISSUED		TITLE		
DRAWN BY		Static Seal Guide (Part No-12)		
CHECKED BY				
APPROVED BY		SIZE	DWG NO.	SHEET REV
		A3	High pressure Seal Guide Front Drawing	A
		SCALE 1:1	SHEET 1 OF 1	

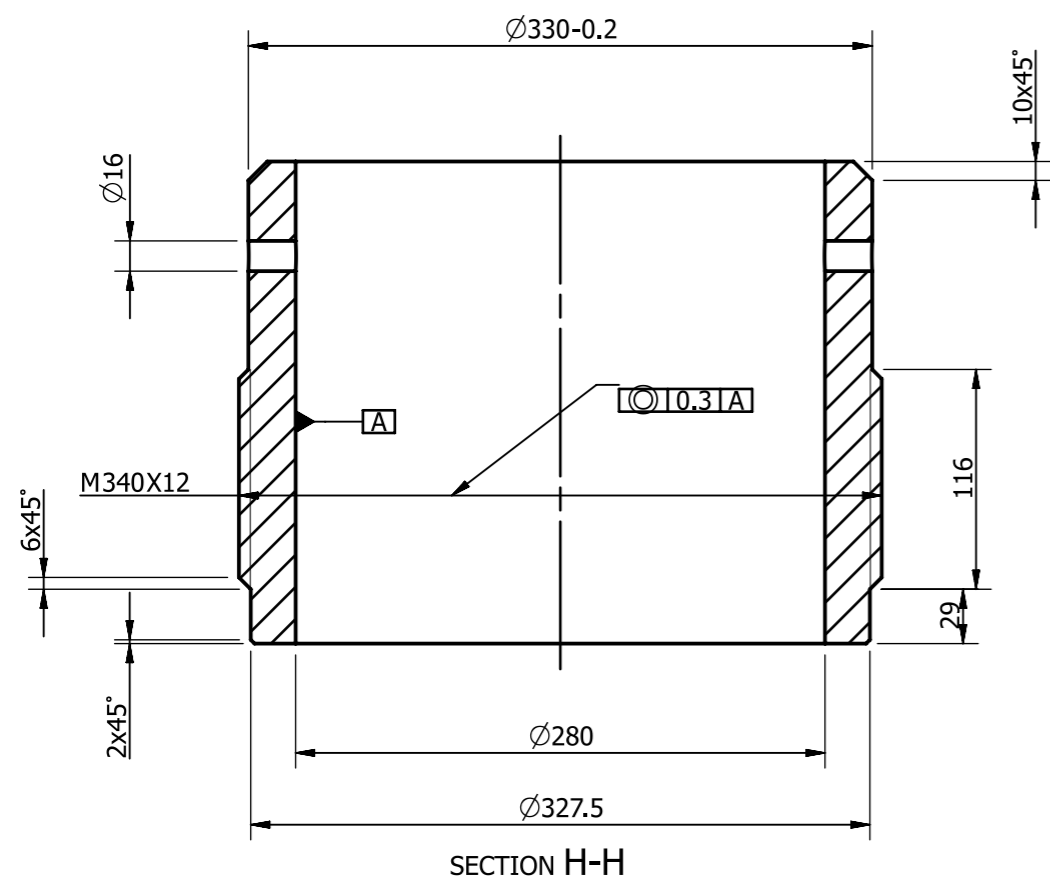
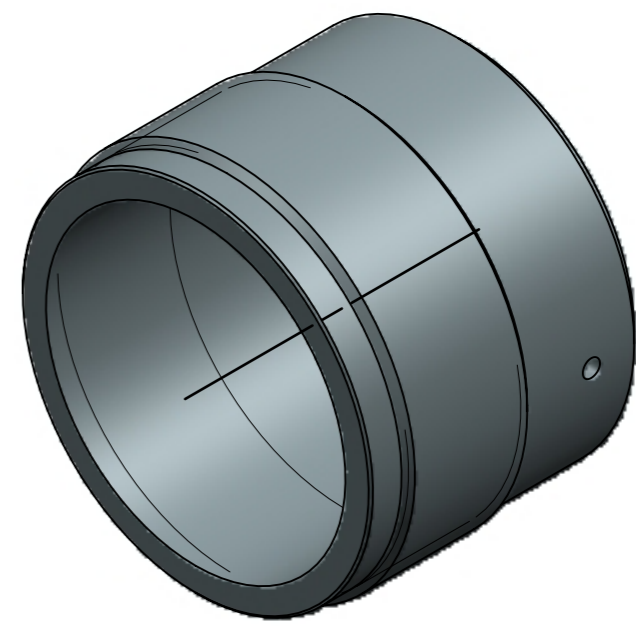
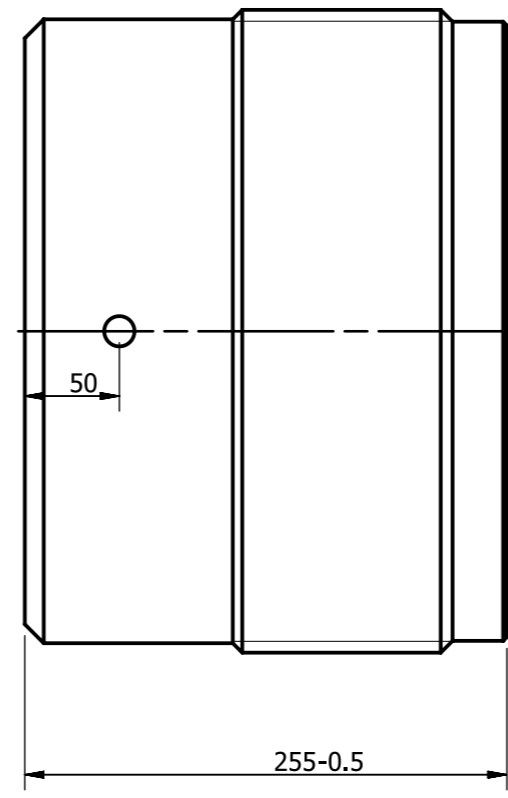
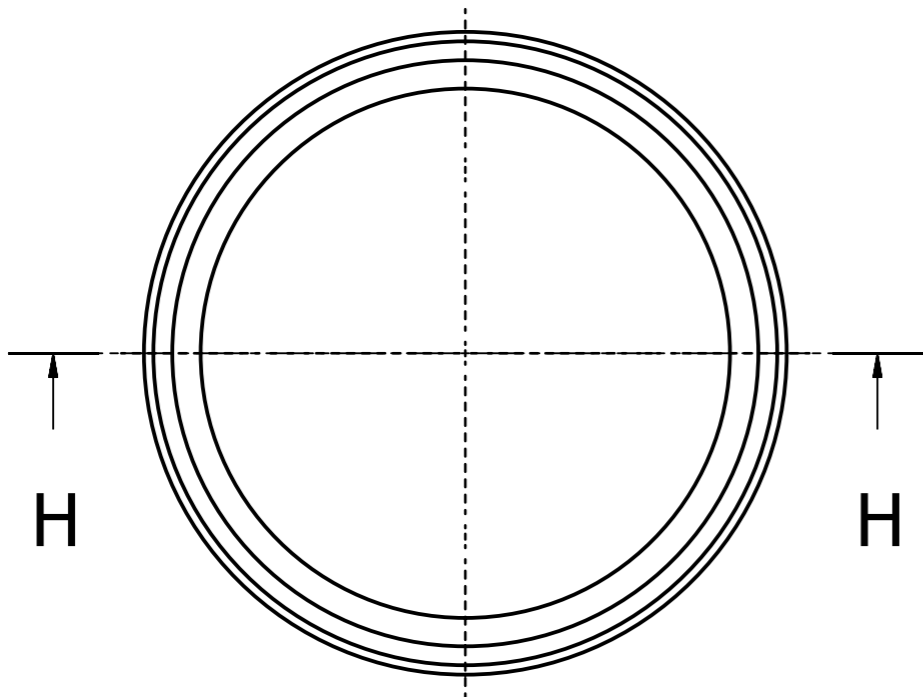

NOTE-All Dimension are in mm
Remove all sharp corners

Permissible deviations for linear dimensions except for broken edges									
Tolerance class		0.5 upto 3	over 3 upto 6	over 6 upto 30	over 30 upto 120	over 120 upto 400	over 400 upto 1000	over 1000 upto 2000	over 2000 upto 4000
Designation	Description								
m	medium	±0.1	±0.1	±0.2	±0.3	±0.5	±0.8	±1.2	±2

MATERIAL		I.I.T KANPUR		
M.S				
FIRST ISSUED		TITLE		
DRAWN BY		FRONT BOLT (Part No-13)		
CHECKED BY				
APPROVED BY		SIZE	DWG NO.	SHEET REV
		A3	Bolt_Front_Push_N_2020	A
		SHEET 1 OF 1		

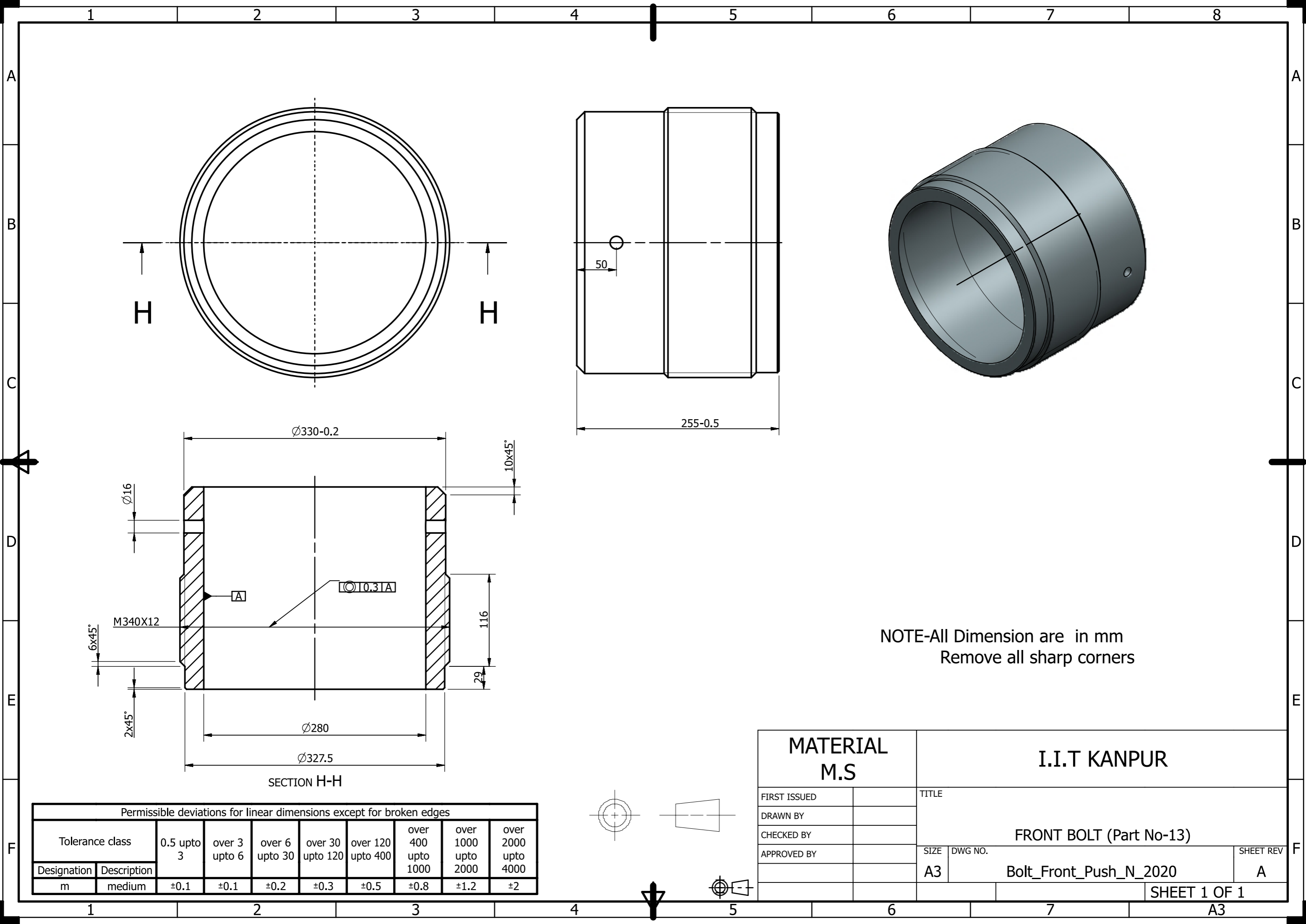
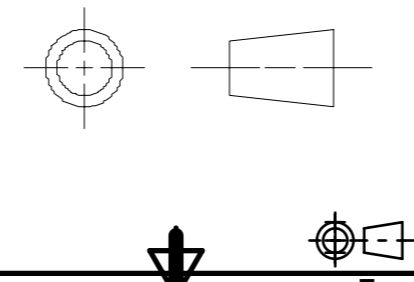

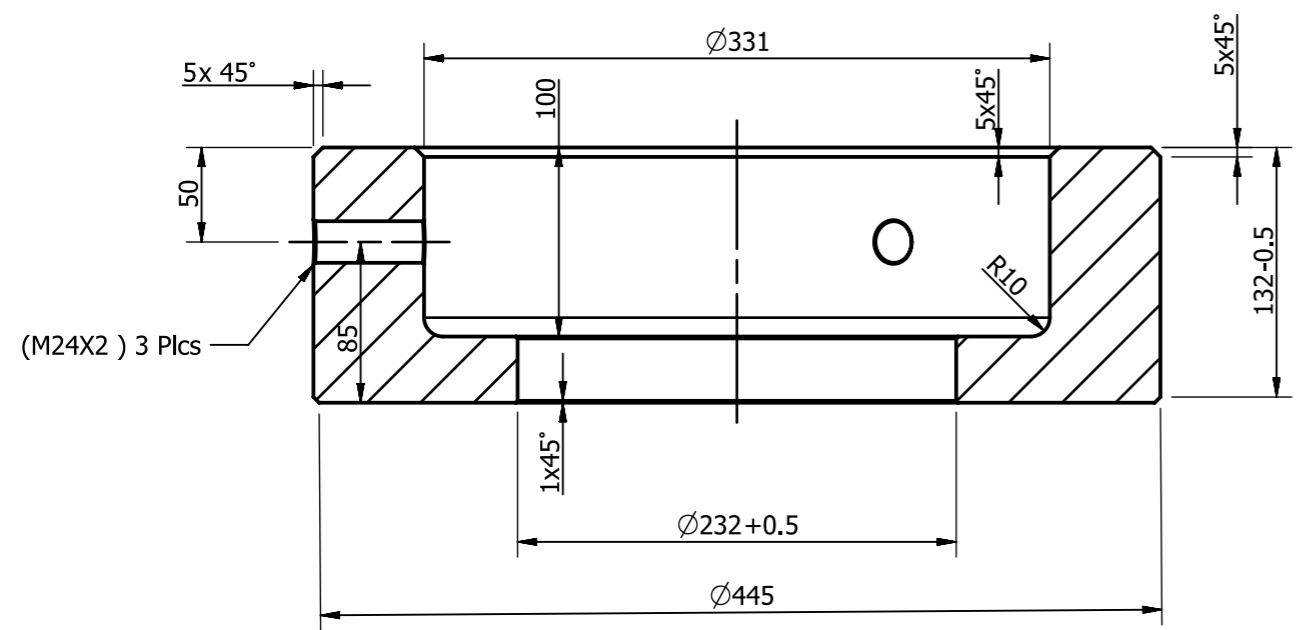
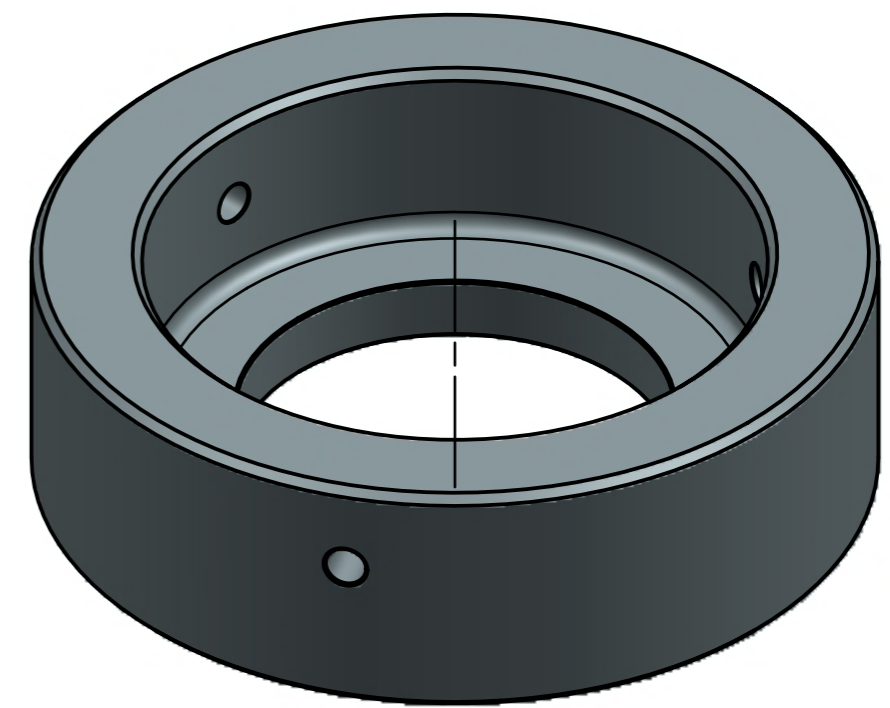
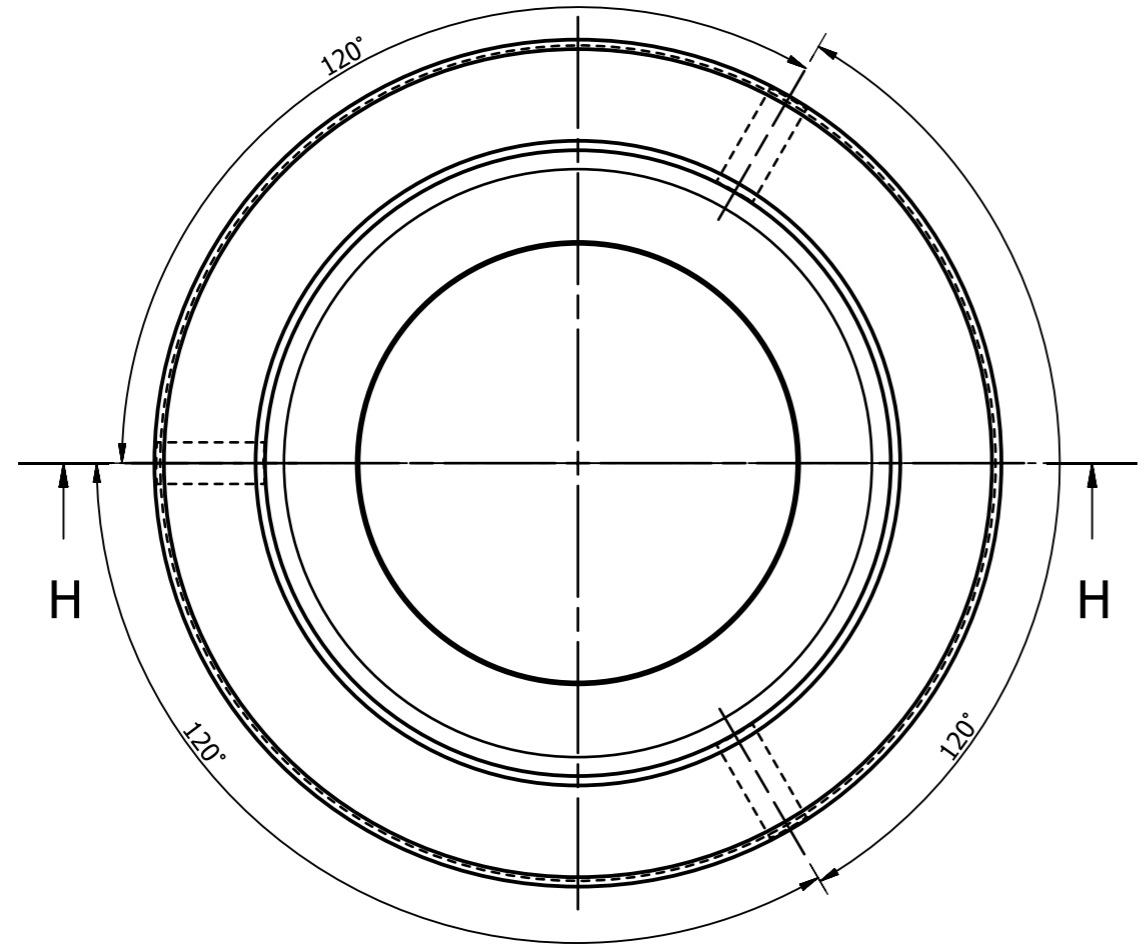

SECTION H-H

Note-Remove all sharp corners
Hardnes test report required

MATERIAL BS970-3:1991 817 M40 Heat treated to "T" condition		I.I.T KANPUR		
FIRST ISSUED		TITLE		
DRAWN BY		FRONT_BOLT_COVER (Part No-14)		
CHECKED BY		SIZE	DWG NO.	SHEET REV
APPROVED BY		A3	Bolt front push cover drawing	A
		SCALE 1:1	SHEET 1 OF 1	

Permissible deviations for linear dimensions except for broken edges									
Tolerance class		0.5 upto 3	over 3 upto 6	over 6 upto 30	over 30 upto 120	over 120 upto 400	over 400 upto 1000	over 1000 upto 2000	over 2000 upto 4000
Designation	Description	±0.1	±0.1	±0.2	±0.3	±0.5	±0.8	±1.2	±2
m	medium								

ALL DIMENSIONS IN MM

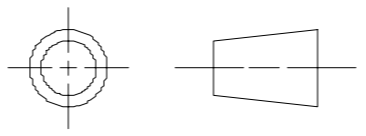

Grid lines: 1, 2, 3, 4, 5, 6, 7, 8 (horizontal); A, B, C, D, E, F (vertical)

REVISION

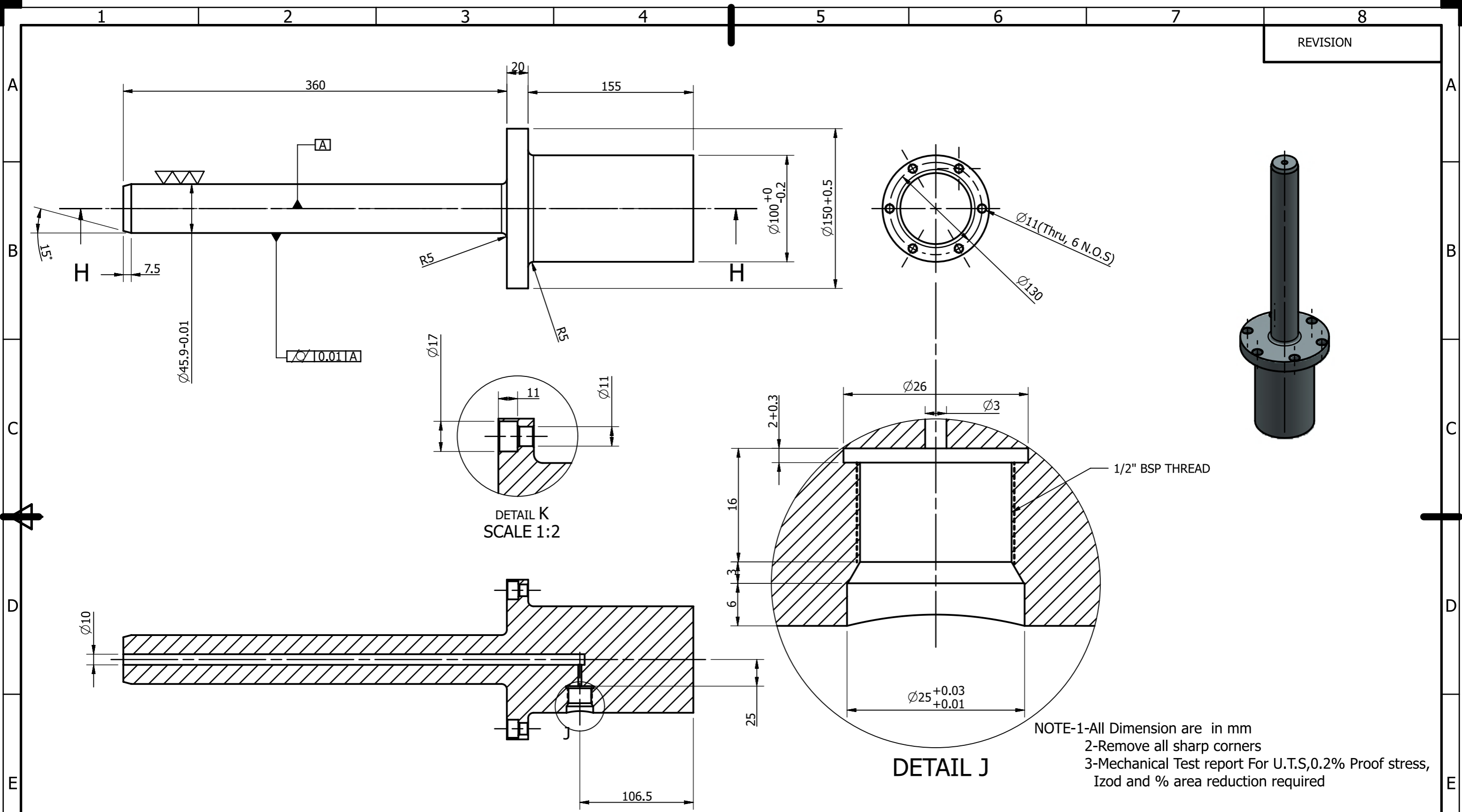

NOTE-1-All Dimension are in mm
 2-Remove all sharp corners
 3-Mechanical Test report For U.T.S,0.2% Proof stress, Izod and % area reduction required

SECTION H-H

DETAIL J

DETAIL K
SCALE 1:2

Permissible deviations for linear dimensions except for broken edges									
Tolerance class		0.5 upto 3	over 3 upto 6	over 6 upto 30	over 30 upto 120	over 120 upto 400	over 400 upto 1000	over 1000 upto 2000	over 2000 upto 4000
Designation	Description								
m	medium	±0.1	±0.1	±0.2	±0.3	±0.5	±0.8	±1.2	±2

MATERIAL BS 970-3:1991 817 M40 " U" Condition		I.I.T KANPUR		
FIRST ISSUED		TITLE		
DRAWN BY		Piston (PART NO-15)		
CHECKED BY		SIZE	DWG NO.	SHEET REV
APPROVED BY		A3	Piston_N_V2_2020_drawing	A
SHEET 1 OF 1				

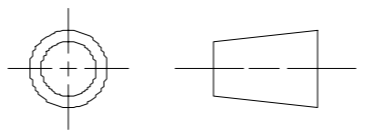

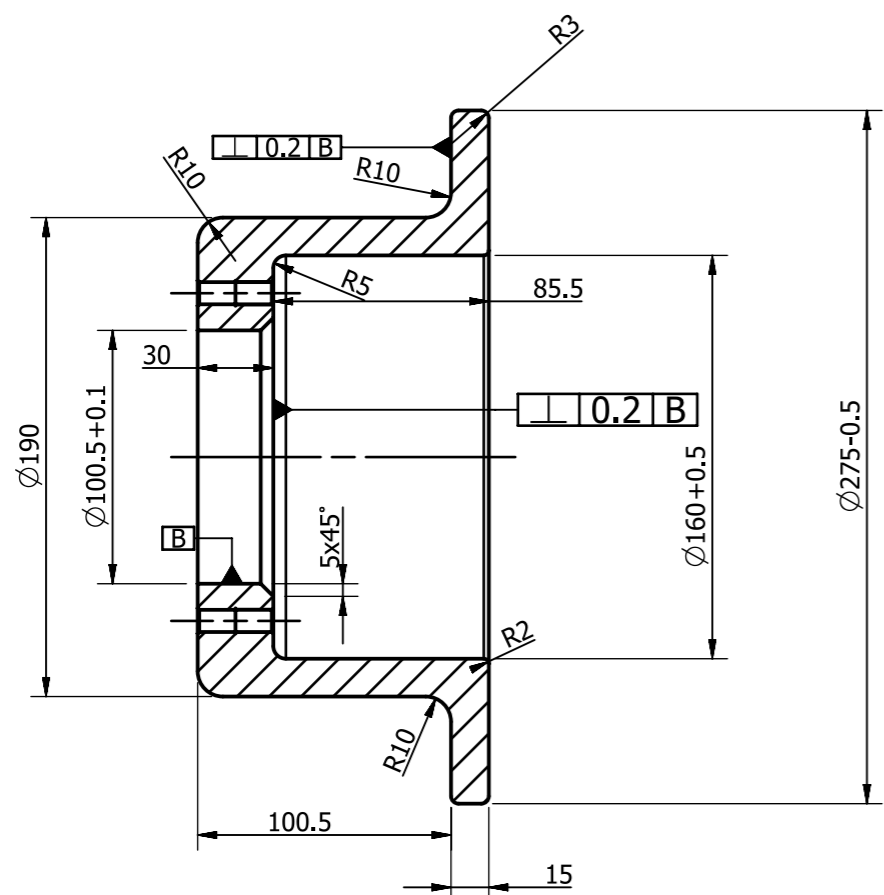
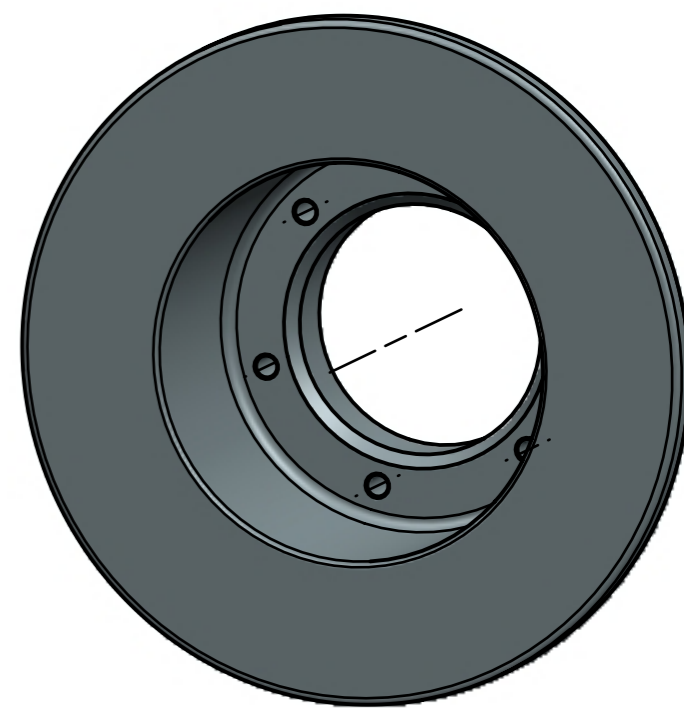
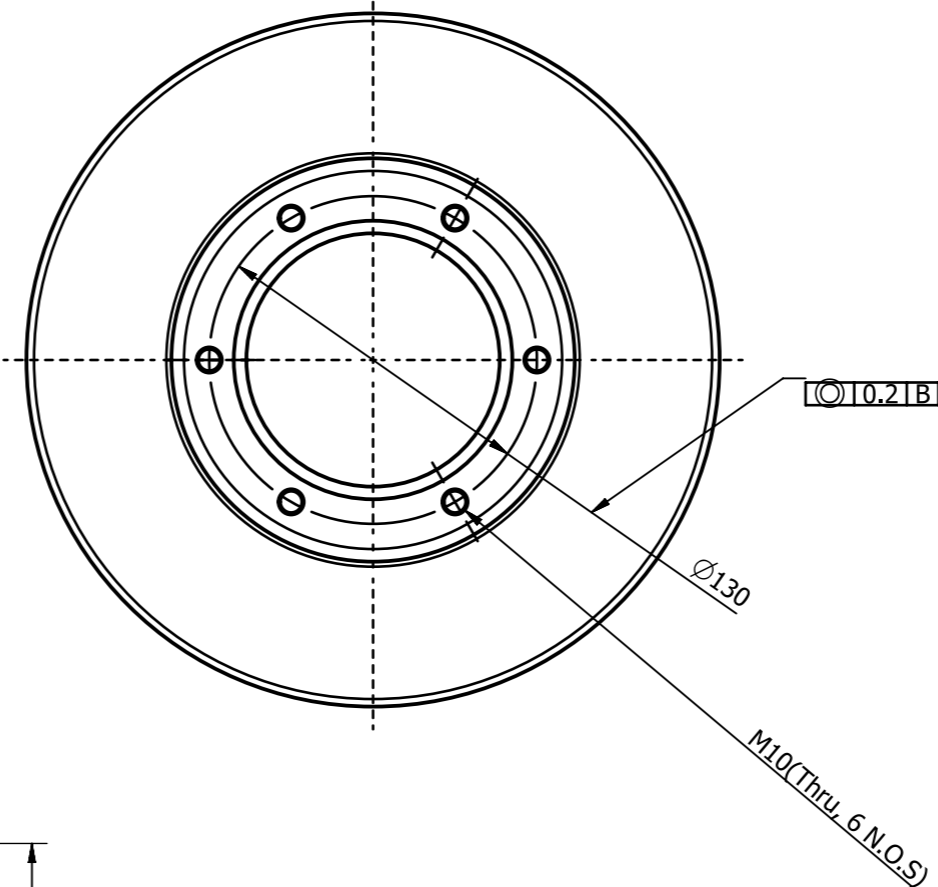
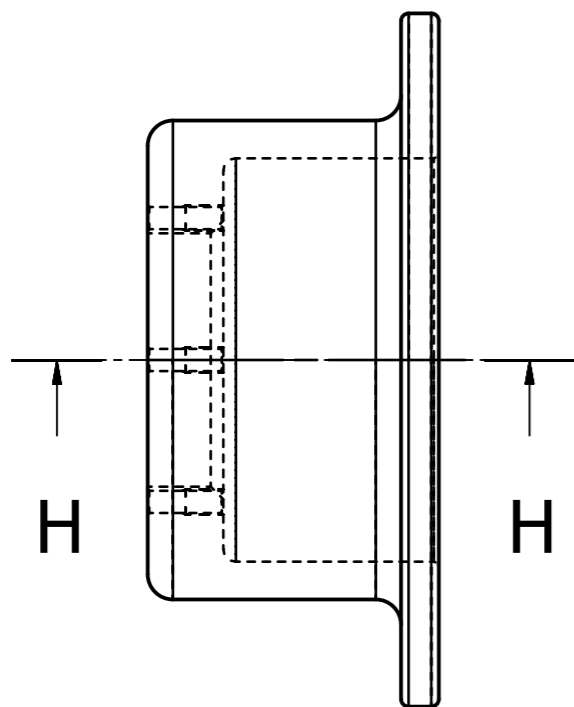

SECTION H-H

Note-Remove all sharp corners
Hardnes test report required

Permissible deviations for linear dimensions except for broken edges

Tolerance class	0.5 upto 3	over 3 upto 6	over 6 upto 30	over 30 upto 120	over 120 upto 400	over 400 upto 1000	over 1000 upto 2000	over 2000 upto 4000
Designation								
Description								
m	medium	±0.1	±0.1	±0.2	±0.3	±0.5	±0.8	±1.2
								±2

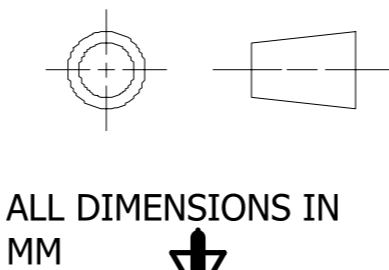

ALL DIMENSIONS IN MM

MATERIAL BS970-3:1991 (817 M40 "W "condition)		I.I.T KANPUR		
FIRST ISSUED		TITLE		
DRAWN BY		PISTON_MASS (Part No-16)		
CHECKED BY		SIZE	DWG NO.	SHEET REV
APPROVED BY		A3	Piston Mass Drawing	A
		SCALE 1:1	SHEET 1 OF 1	

1 2 3 4 5 6 7 8

A B C D E F

A B C D E F

REVISION

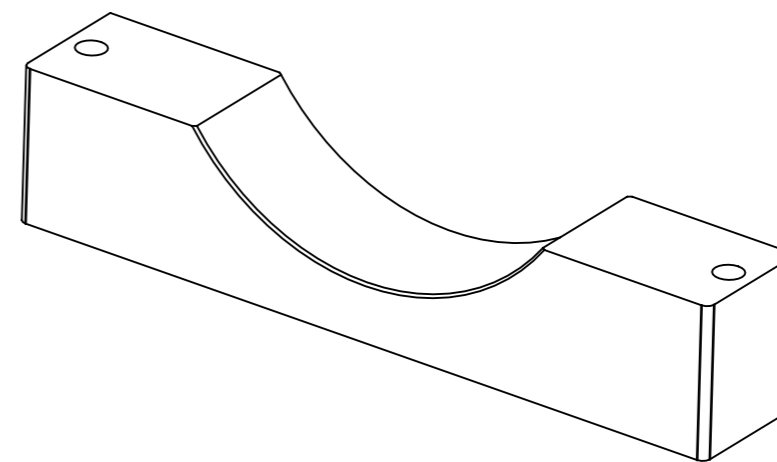
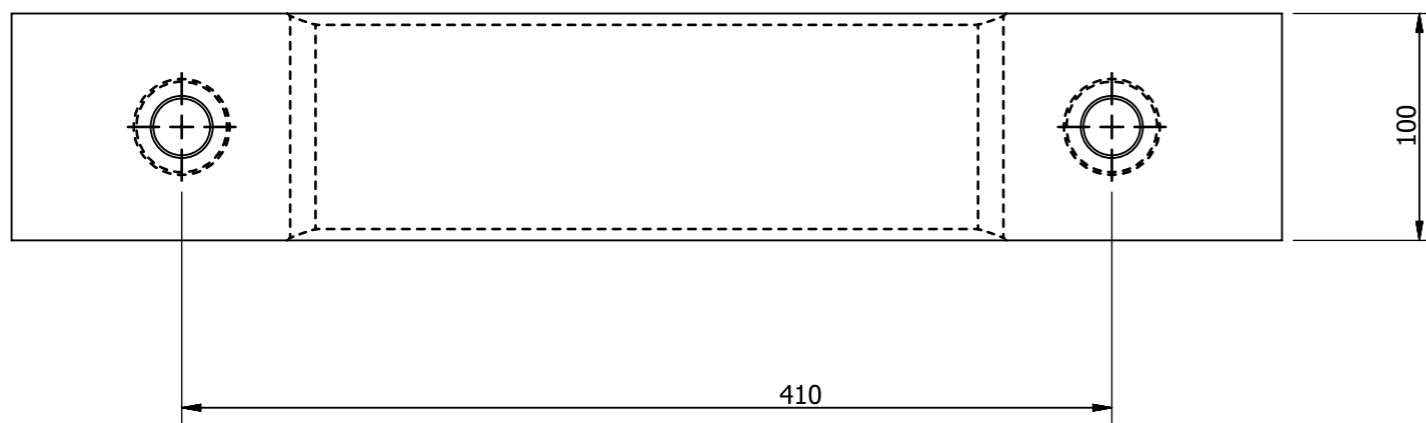
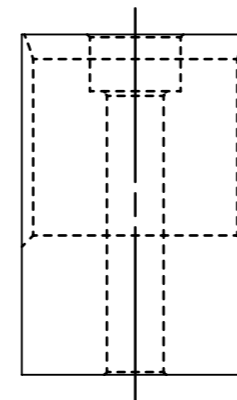
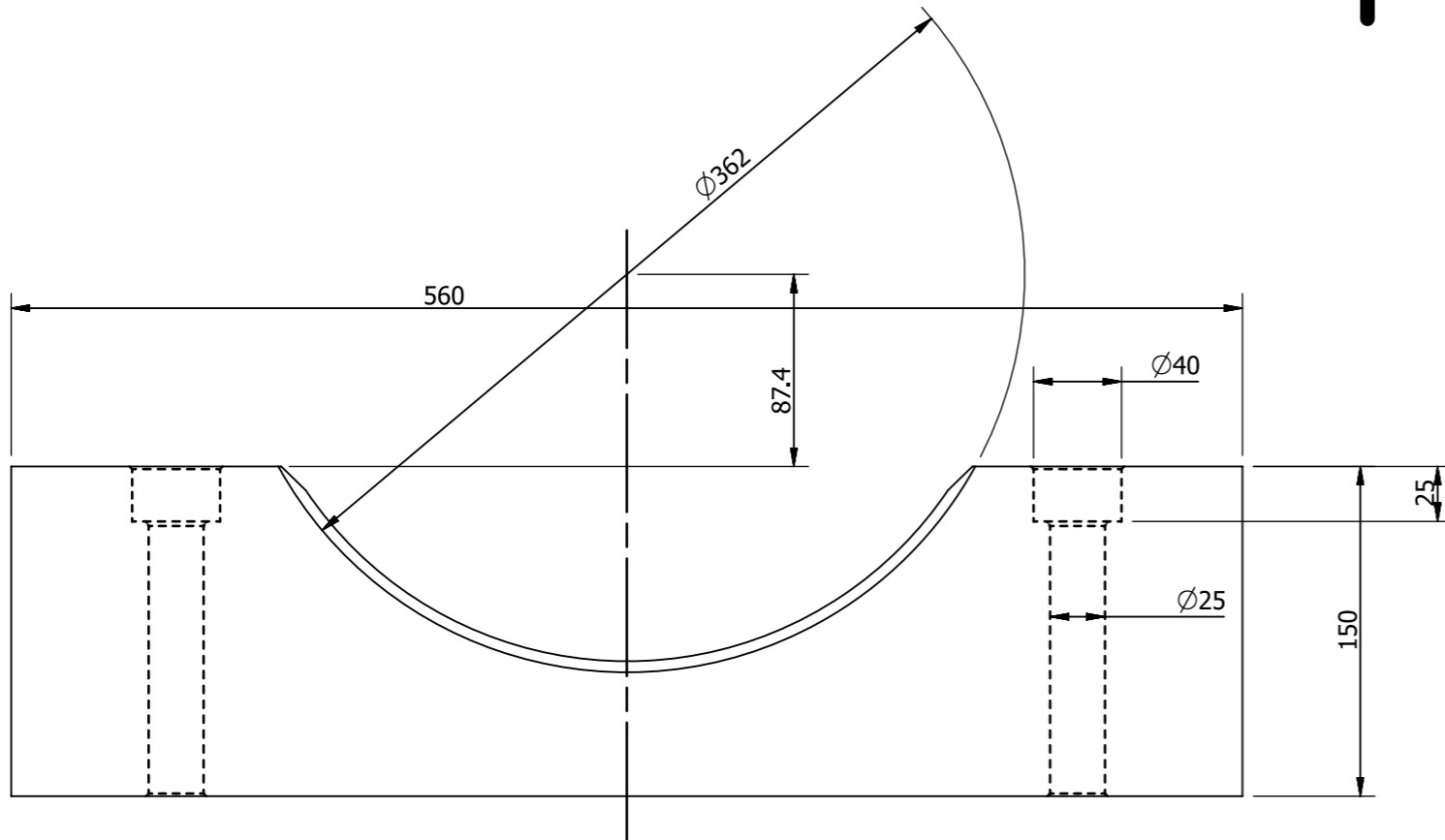

Permissible deviations for linear dimensions except for broken edges									
Tolerance class		0.5 upto 3	over 3 upto 6	over 6 upto 30	over 30 upto 120	over 120 upto 400	over 400 upto 1000	over 1000 upto 2000	over 2000 upto 4000
Designation	Description								
m	medium	±0.1	±0.1	±0.2	±0.3	±0.5	±0.8	±1.2	±2

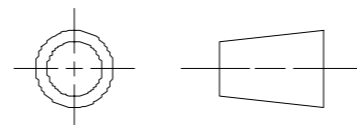

MATERIAL MILD STEEL		I.I.T KANPUR		
FIRST ISSUED		TITLE		
DRAWN BY		Lower Clamp (Part No-17)		
CHECKED BY				
APPROVED BY		SIZE	DWG NO.	SHEET REV
		A3	Lower Clamp_N_V2_2020_drawing	A
				SHEET 1 OF 1

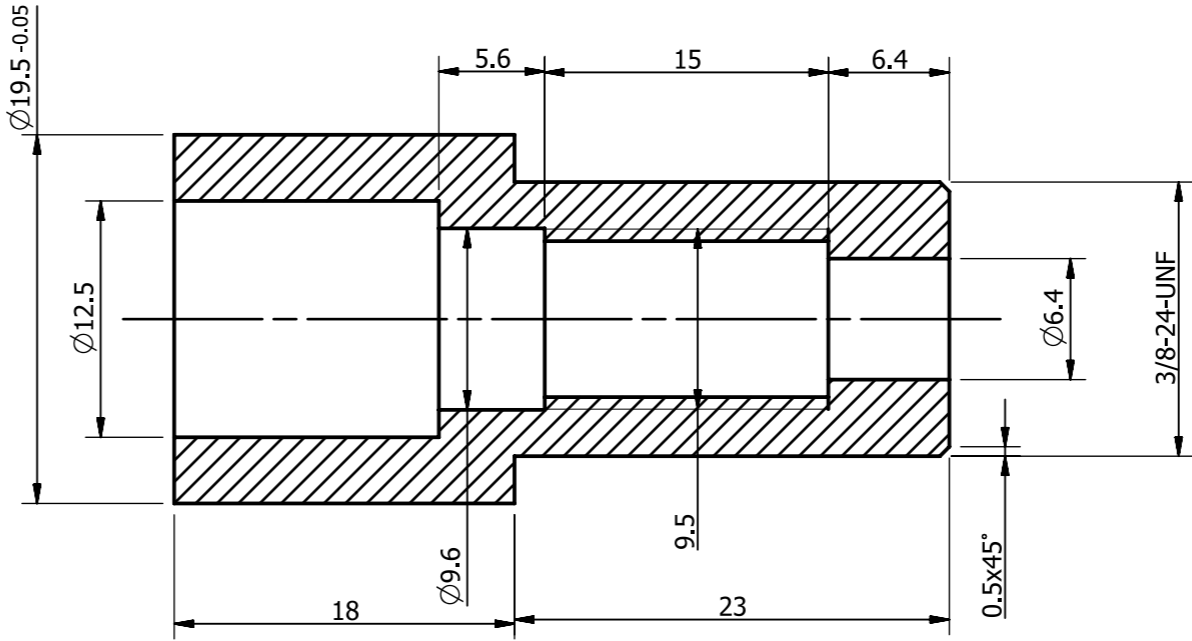
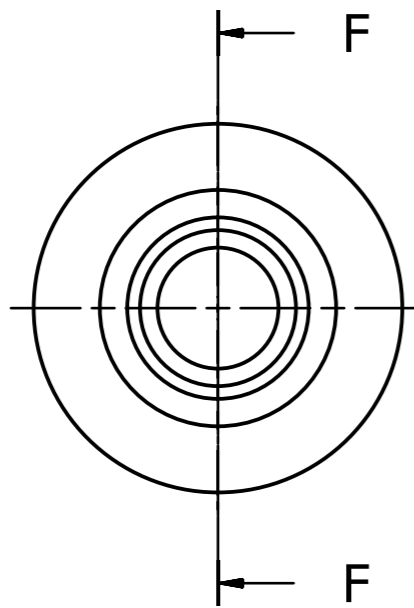

SECTION F-F

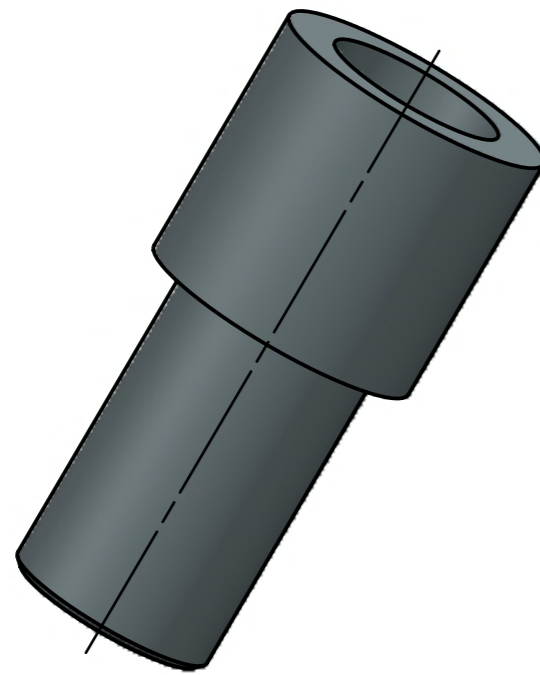

Permissible deviations for linear dimensions except for broken edges									
Tolerance class		0.5 upto 3	over 3 upto 6	over 6 upto 30	over 30 upto 120	over 120 upto 400	over 400 upto 1000	over 1000 upto 2000	over 2000 upto 4000
Designation	Description								
m	medium	±0.1	±0.1	±0.2	±0.3	±0.5	±0.8	±1.2	±2

ALL DIMENSIONS IN MM

MATERIAL EN-24 "W" Condition		I.I.T KANPUR		
FIRST ISSUED		TITLE		
DRAWN BY		Sensor Holder (PART NO-18)		
CHECKED BY		SIZE	DWG NO.	SHEET REV
APPROVED BY		A3	Sensor Holder Drawing	A
		SCALE 1:1	SHEET 1 OF 1	

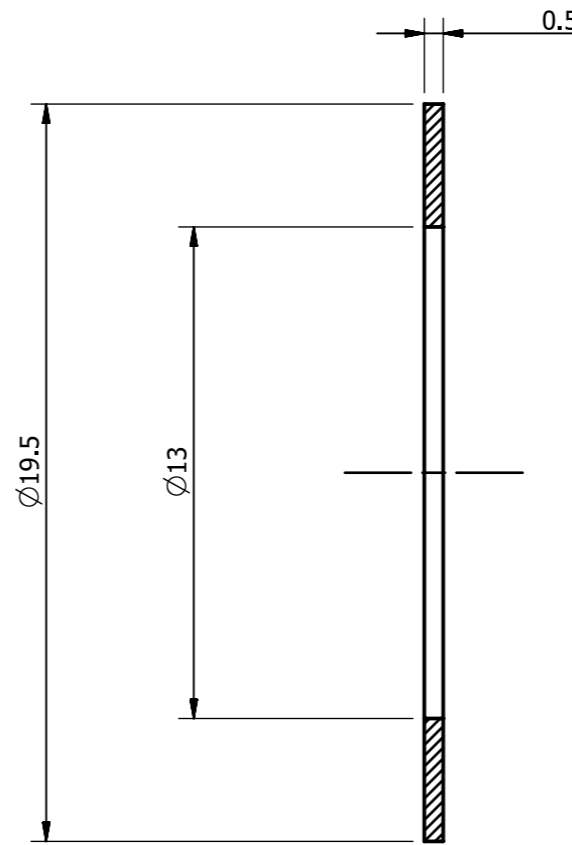
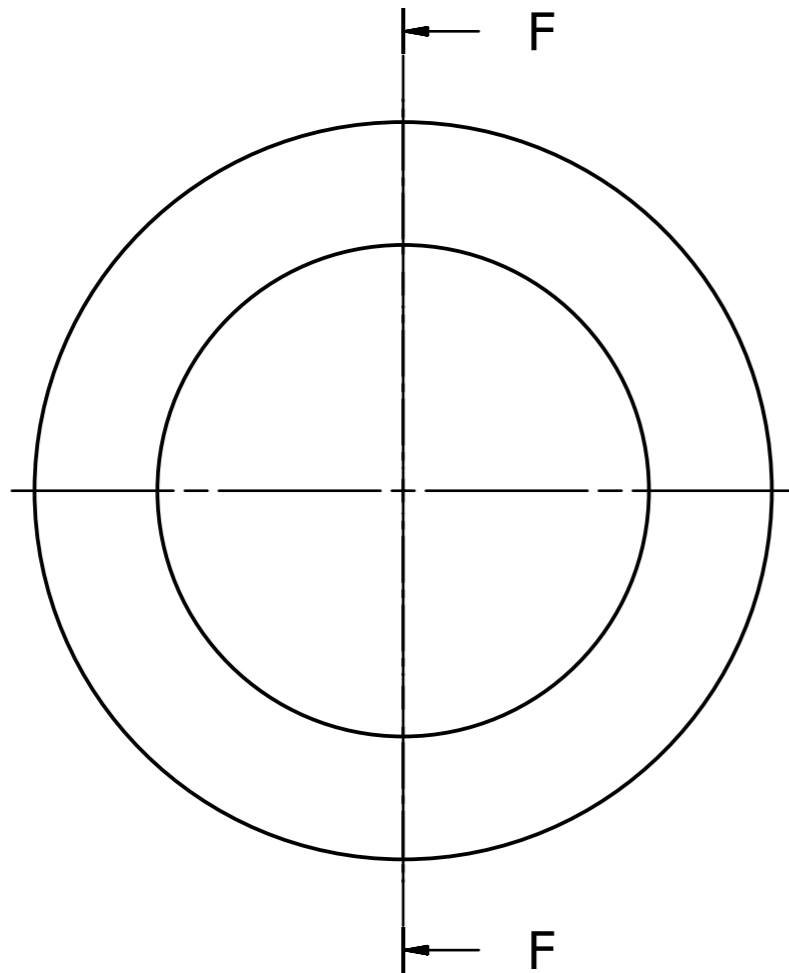

SECTION F-F

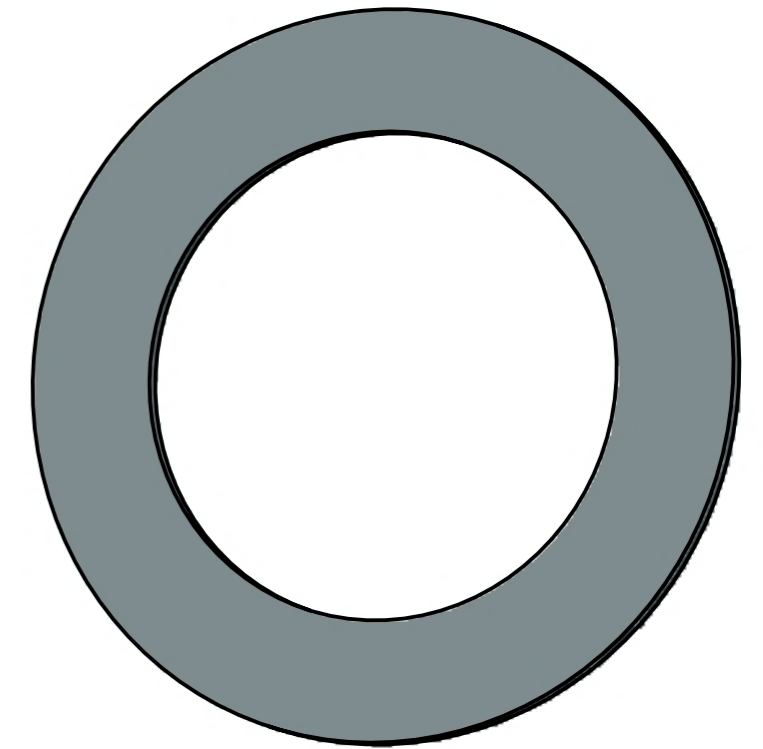

Permissible deviations for linear dimensions except for broken edges									
Tolerance class		0.5 upto 3	over 3 upto 6	over 6 upto 30	over 30 upto 120	over 120 upto 400	over 400 upto 1000	over 1000 upto 2000	over 2000 upto 4000
Designation	Description								
m	medium	±0.1	±0.1	±0.2	±0.3	±0.5	±0.8	±1.2	±2

ALL DIMENSIONS IN MM

MATERIAL Mild Steel		I.I.T KANPUR			
FIRST ISSUED		TITLE			
DRAWN BY		Lower Seal Washer (PART NO-19)			
CHECKED BY					
APPROVED BY		SIZE	DWG NO.	SHEET REV	
		A3	Lower Seal Washer Drawing	A	
		SCALE 1:1	SHEET 1 OF 1		

1 2 3 4 5 6 7 8

A

B

C

D

E

F

A

B

C

D

E

F

A3

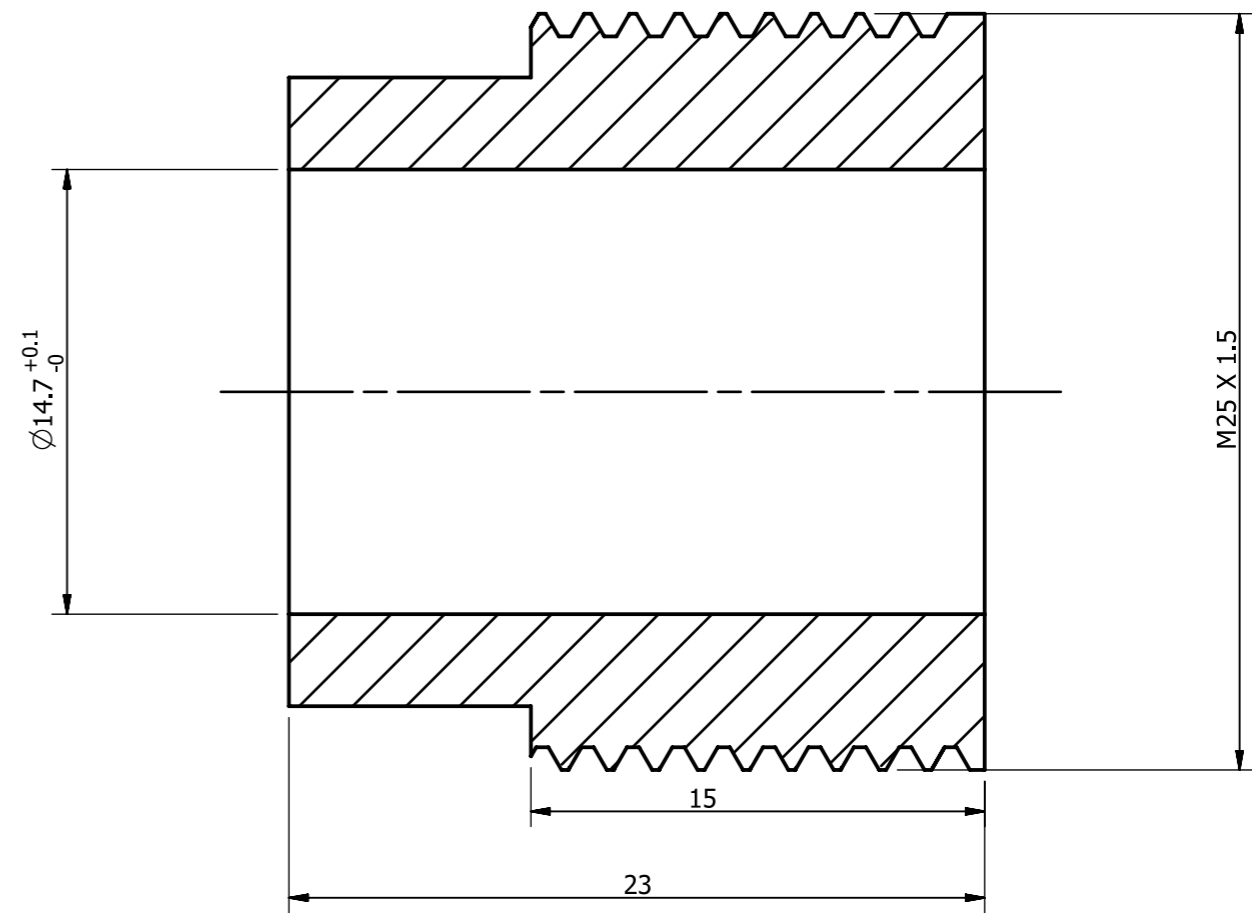
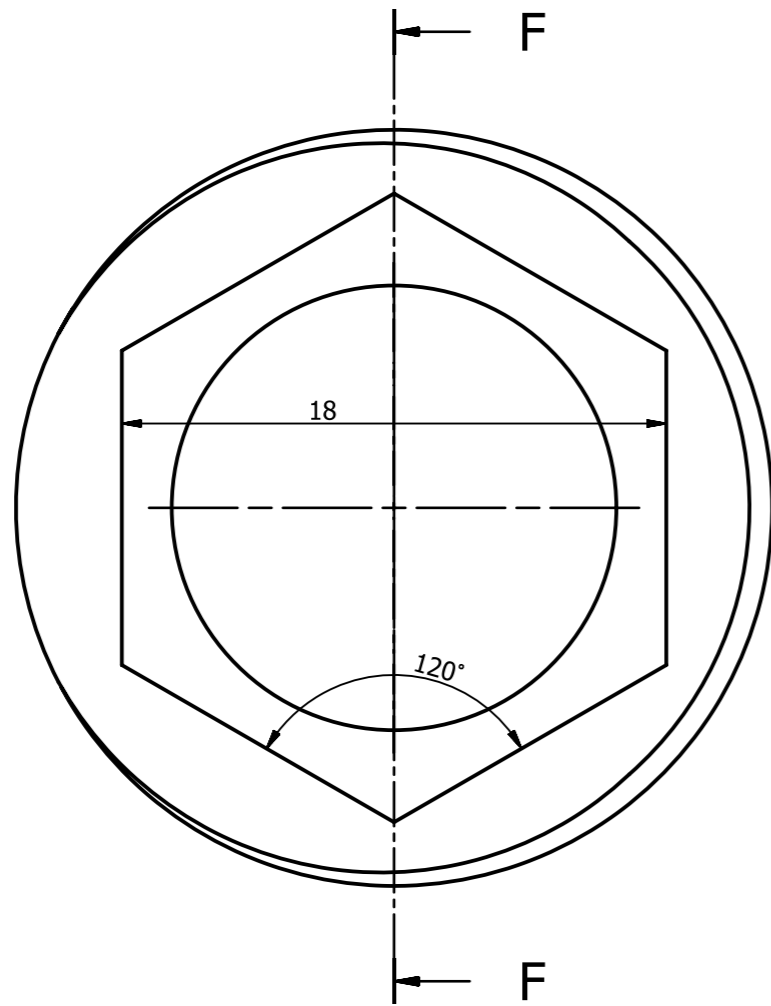

SECTION F-F

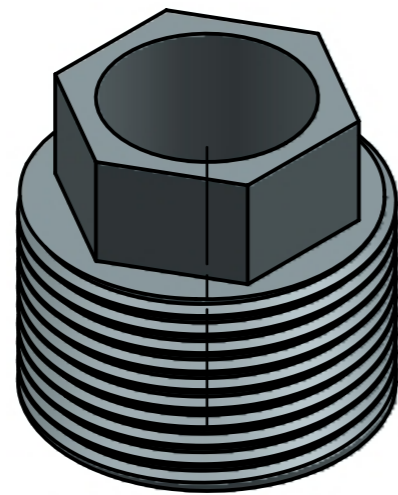

Permissible deviations for linear dimensions except for broken edges									
Tolerance class		0.5 upto 3	over 3 upto 6	over 6 upto 30	over 30 upto 120	over 120 upto 400	over 400 upto 1000	over 1000 upto 2000	over 2000 upto 4000
Designation	Description								
m	medium	±0.1	±0.1	±0.2	±0.3	±0.5	±0.8	±1.2	±2

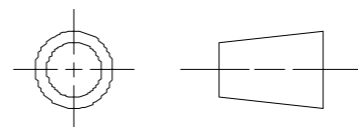

ALL DIMENSIONS IN MM

MATERIAL EN-24 "W" Condition		I.I.T KANPUR		
FIRST ISSUED		TITLE		
DRAWN BY		Sensor Holder Threaded Part (PART NO-20)		
CHECKED BY		SIZE	DWG NO.	SHEET REV
APPROVED BY		A3	Sensor Holder Threaded Part Drawing	A
		SCALE 1:1		SHEET 1 OF 1

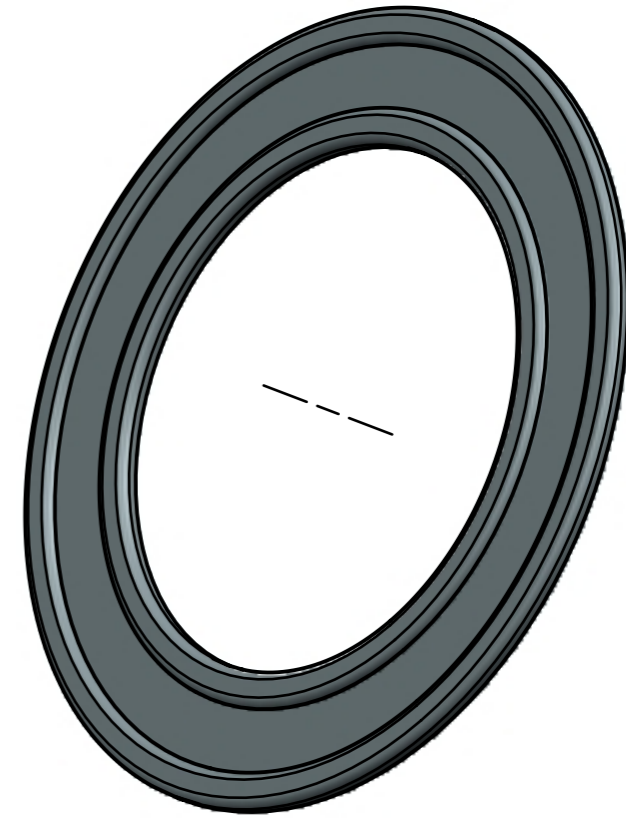
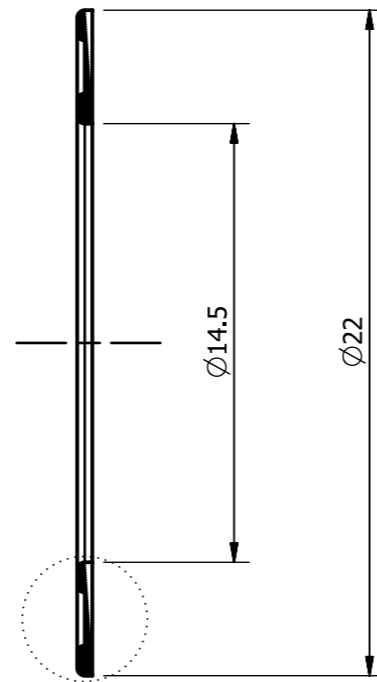
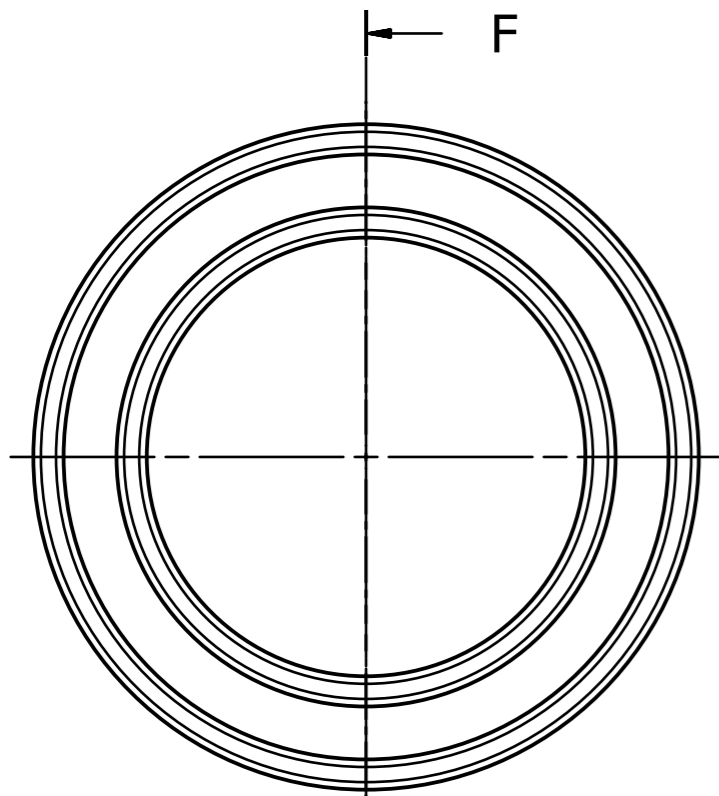

G SECTION F-F

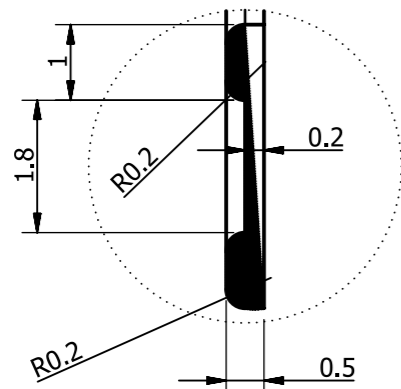

DETAIL G
SCALE 10:1

Permissible deviations for linear dimensions except for broken edges									
Tolerance class		0.5 upto 3	over 3 upto 6	over 6 upto 30	over 30 upto 120	over 120 upto 400	over 400 upto 1000	over 1000 upto 2000	over 2000 upto 4000
Designation	Description	±0.1	±0.1	±0.2	±0.3	±0.5	±0.8	±1.2	±2
m	medium								

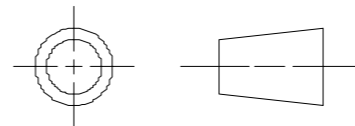

ALL DIMENSIONS IN
MM

MATERIAL BRASS		I.I.T KANPUR			
FIRST ISSUED		TITLE			
DRAWN BY		Upper Seal Washer (PART NO-21)			
CHECKED BY					
APPROVED BY		SIZE	DWG NO.	SHEET REV	
		A3	Upper Seal Washer Sensor Holder Drawing	A	
SCALE 1:1			SHEET 1 OF 1		

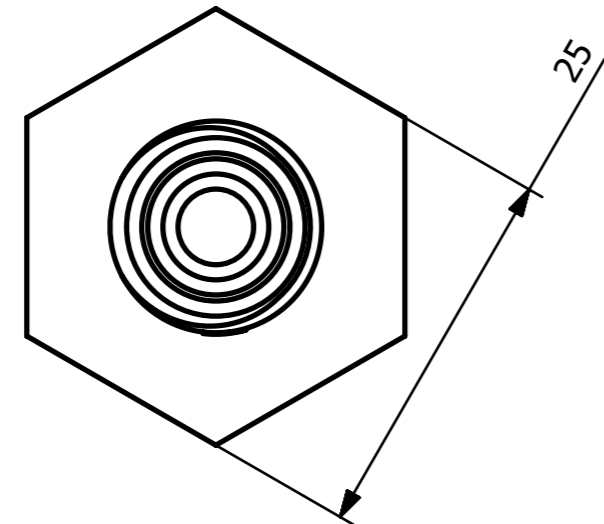
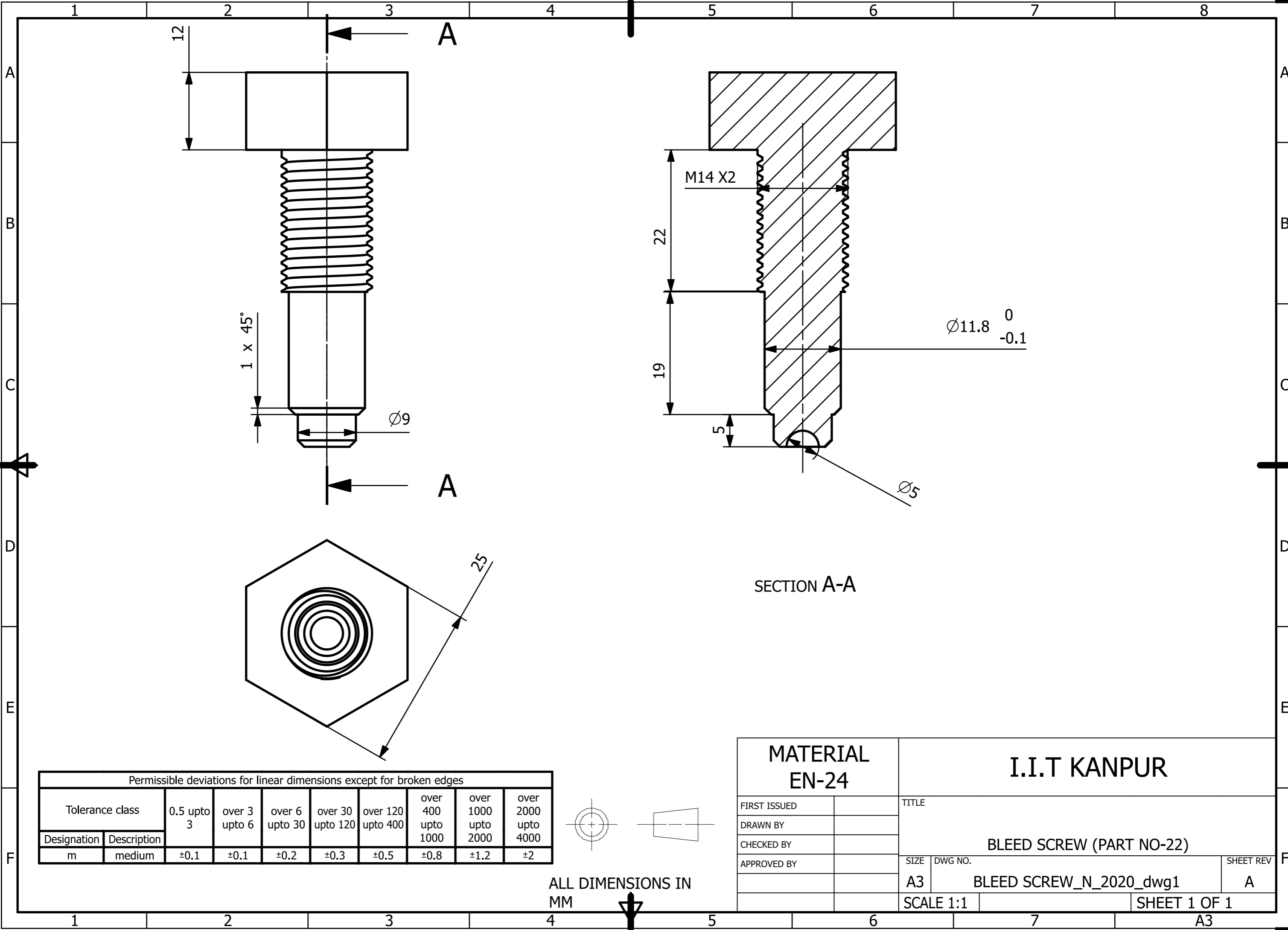

SECTION A-A

Permissible deviations for linear dimensions except for broken edges									
Tolerance class		0.5 upto 3	over 3 upto 6	over 6 upto 30	over 30 upto 120	over 120 upto 400	over 400 upto 1000	over 1000 upto 2000	over 2000 upto 4000
Designation	Description								
m	medium	±0.1	±0.1	±0.2	±0.3	±0.5	±0.8	±1.2	±2

ALL DIMENSIONS IN MM

MATERIAL EN-24		I.I.T KANPUR		
FIRST ISSUED		TITLE		
DRAWN BY		BLEED SCREW (PART NO-22)		
CHECKED BY				
APPROVED BY		SIZE	DWG NO.	SHEET REV
		A3	BLEED SCREW_N_2020_dwg1	A
		SCALE 1:1	SHEET 1 OF 1	

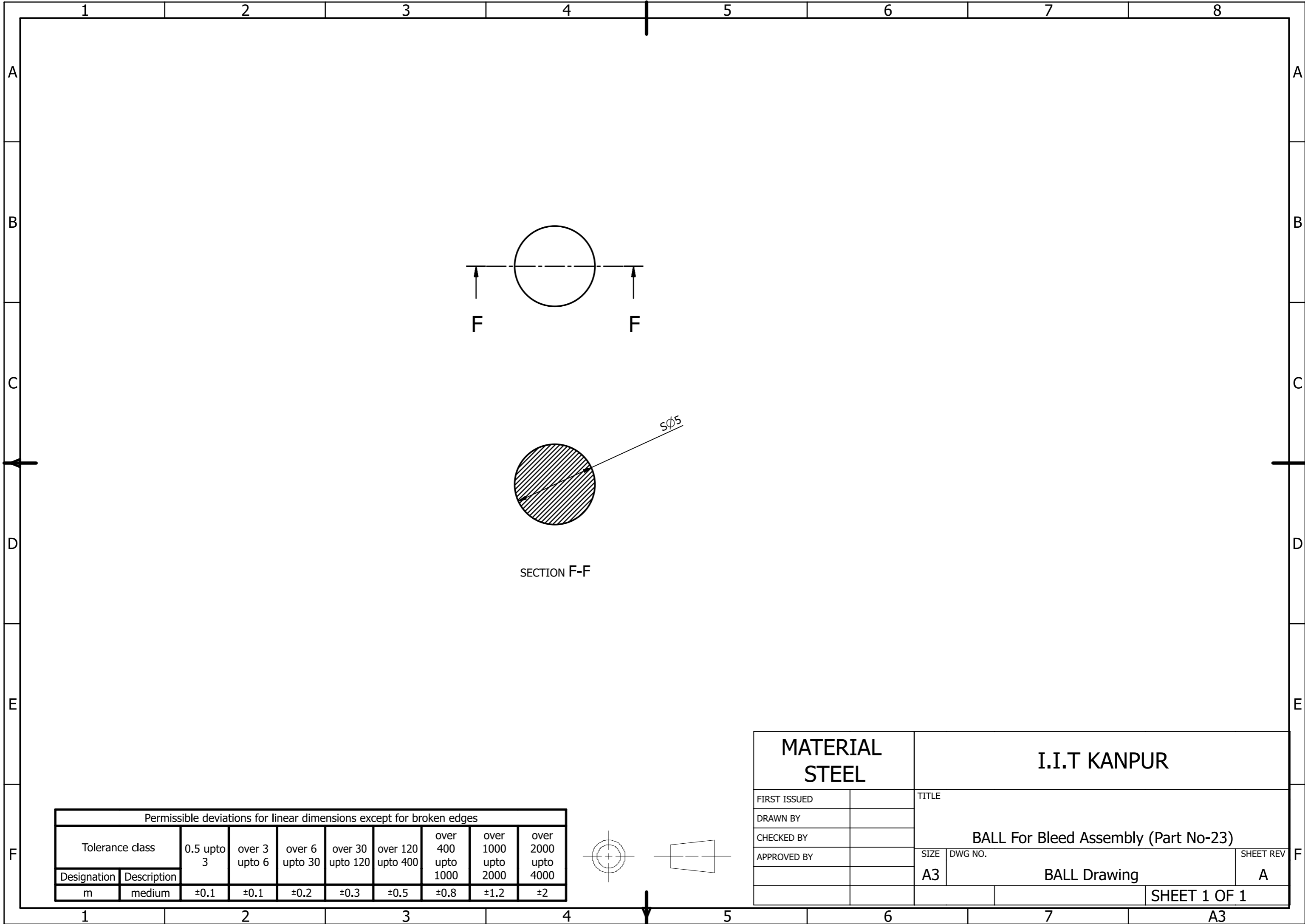

SECTION F-F

SØ5

Permissible deviations for linear dimensions except for broken edges									
Tolerance class		0.5 upto 3	over 3 upto 6	over 6 upto 30	over 30 upto 120	over 120 upto 400	over 400 upto 1000	over 1000 upto 2000	over 2000 upto 4000
Designation	Description								
m	medium	±0.1	±0.1	±0.2	±0.3	±0.5	±0.8	±1.2	±2

MATERIAL STEEL		I.I.T KANPUR		
FIRST ISSUED		TITLE		
DRAWN BY		BALL For Bleed Assembly (Part No-23)		
CHECKED BY				
APPROVED BY		SIZE	DWG NO.	SHEET REV
		A3	BALL Drawing	A
		SHEET 1 OF 1		

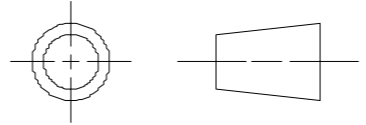

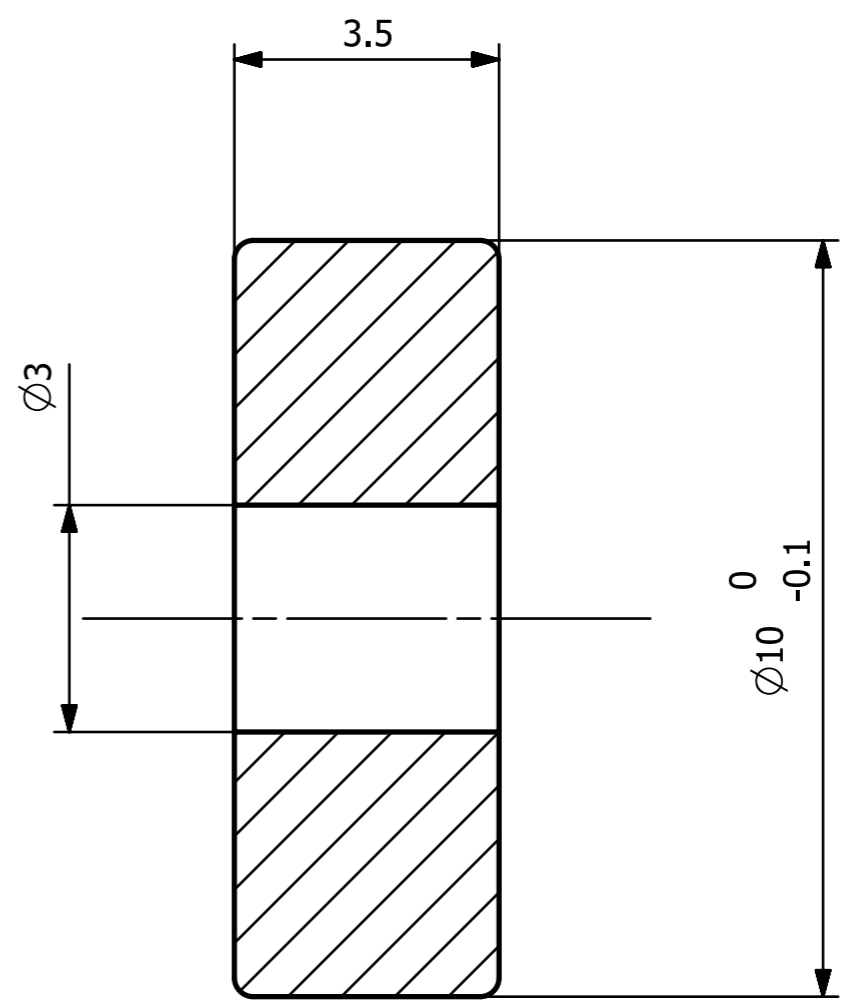
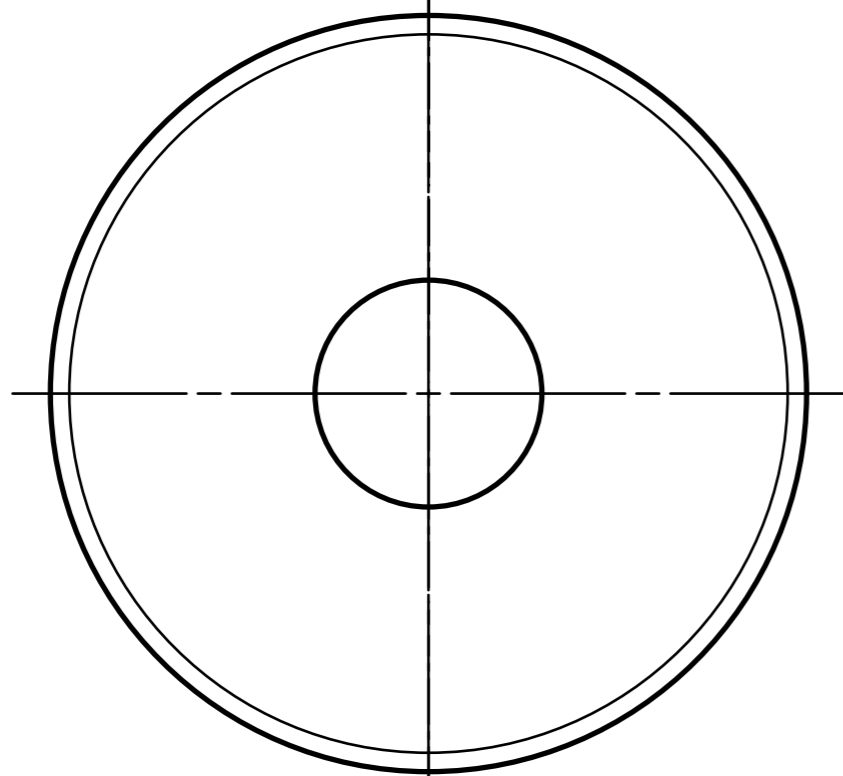

SECTION A-A

Permissible deviations for linear dimensions except for broken edges									
Tolerance class		0.5 upto 3	over 3 upto 6	over 6 upto 30	over 30 upto 120	over 120 upto 400	over 400 upto 1000	over 1000 upto 2000	over 2000 upto 4000
Designation	Description								
m	medium	±0.1	±0.1	±0.2	±0.3	±0.5	±0.8	±1.2	±2

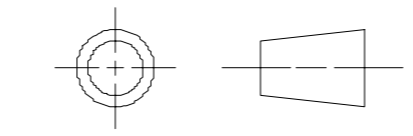

ALL DIMENSIONS IN MM

MATERIAL P.T.F.E		I.I.T KANPUR		
FIRST ISSUED		TITLE		
DRAWN BY		P.T.F.E Seal For Bleed Assembly(Prt No-24)		
CHECKED BY		SIZE	DWG NO.	SHEET REV
APPROVED BY		A3	SEAL FOR BLEED ASSEMBLY(PTFE)_N_2020_dwg1	A
		SCALE 1:1		SHEET 1 OF 1

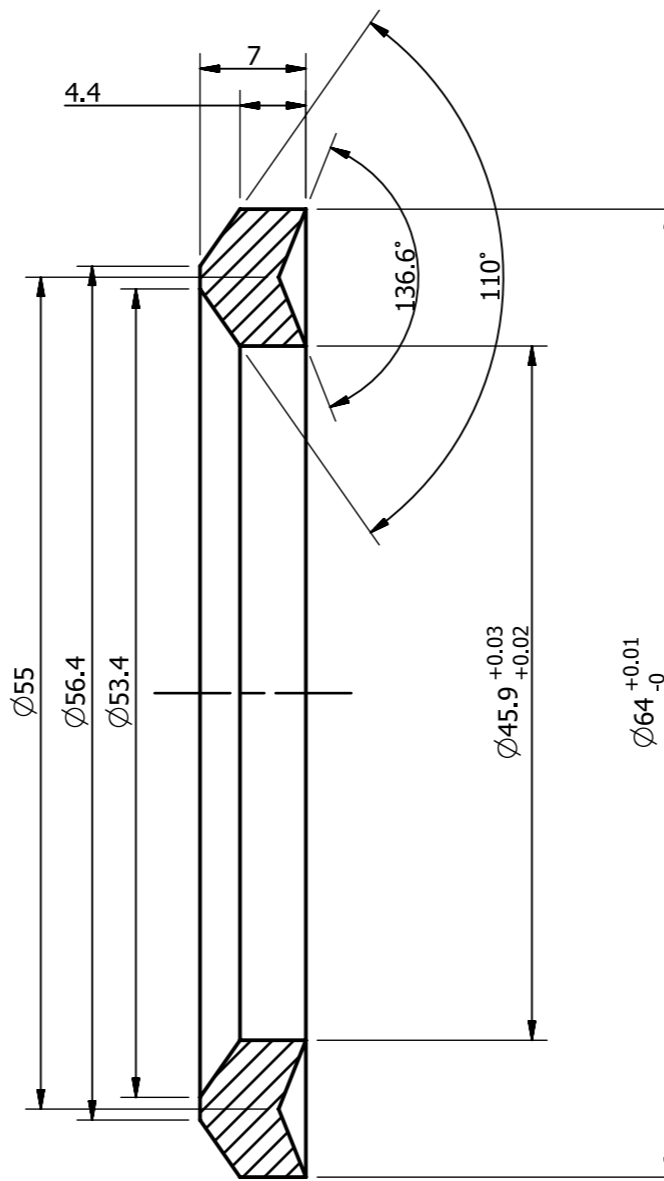
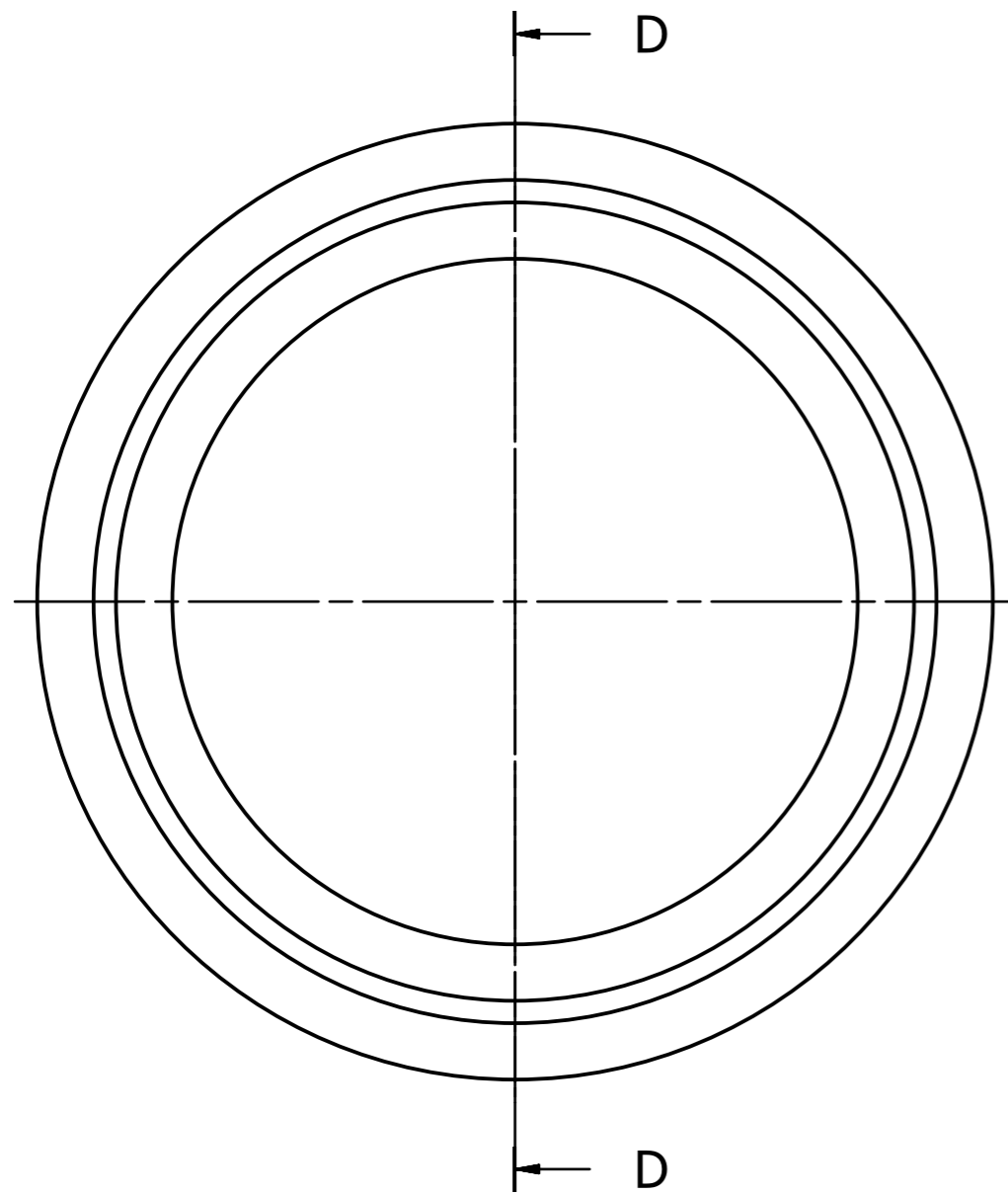

SECTION D-D

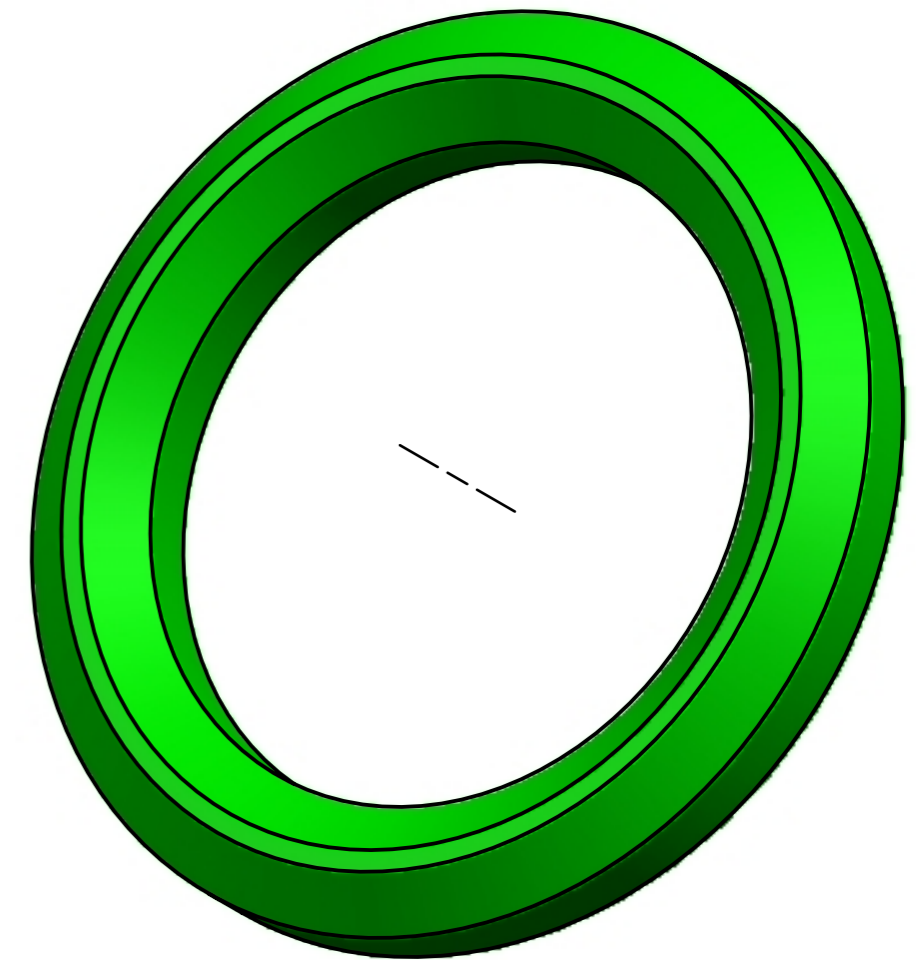

VIEW E
SCALE 2:1

Permissible deviations for linear dimensions except for broken edges									
Tolerance class		0.5 upto 3	over 3 upto 6	over 6 upto 30	over 30 upto 120	over 120 upto 400	over 400 upto 1000	over 1000 upto 2000	over 2000 upto 4000
Designation	Description								
m	medium	±0.1	±0.1	±0.2	±0.3	±0.5	±0.8	±1.2	±2

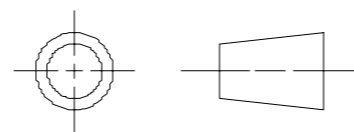

ALL DIMENSIONS IN
MM

MATERIAL BRASS		I.I.T KANPUR		
FIRST ISSUED		TITLE		
DRAWN BY		Dynamic Brass Seal Drawing (Part No-26)		
CHECKED BY				
APPROVED BY		SIZE	DWG NO.	SHEET REV
		A3	Brass Seal Dyanamic Drawing	A
		SCALE 2:1	SHEET 1 OF 1	

A3

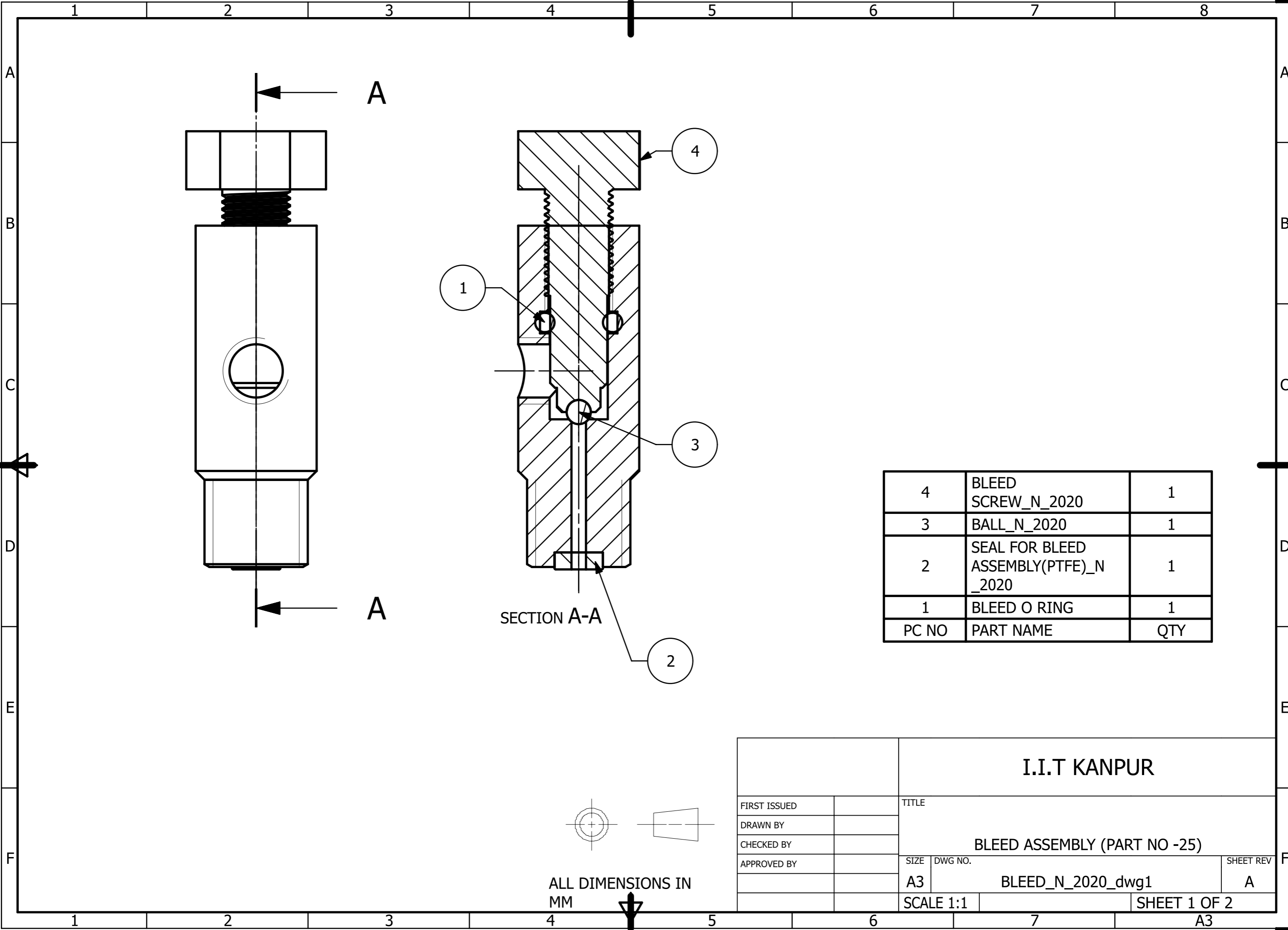

4	BLEED SCREW_N_2020	1
3	BALL_N_2020	1
2	SEAL FOR BLEED ASSEMBLY(PTFE)_N_2020	1
1	BLEED O RING	1
PC NO	PART NAME	QTY

		I.I.T KANPUR		
FIRST ISSUED		TITLE		
DRAWN BY		BLEED ASSEMBLY (PART NO -25)		
CHECKED BY				
APPROVED BY		SIZE	DWG NO.	SHEET REV
		A3	BLEED_N_2020_dwg1	A
		SCALE 1:1	SHEET 1 OF 2	

ALL DIMENSIONS IN MM

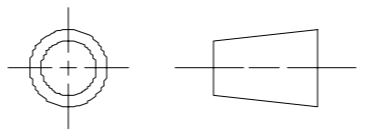

1 2 3 4 5 6 7 8

A A

B B

C C

D D

E E

F F

1 2 3 4 5 6 7 8 A3

1 2 3 4 5 6 7 8

A A

B B

C C

D D

E E

F F

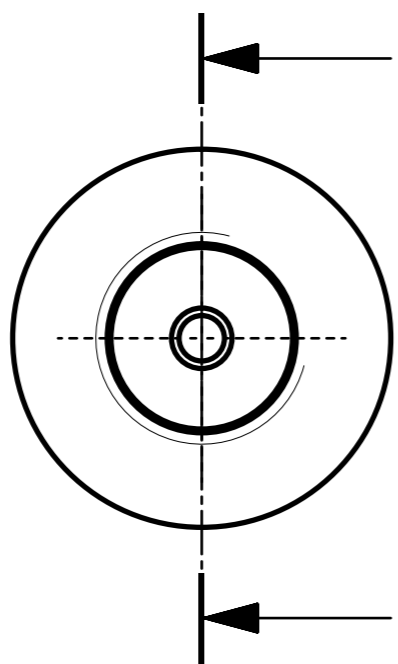

B

B

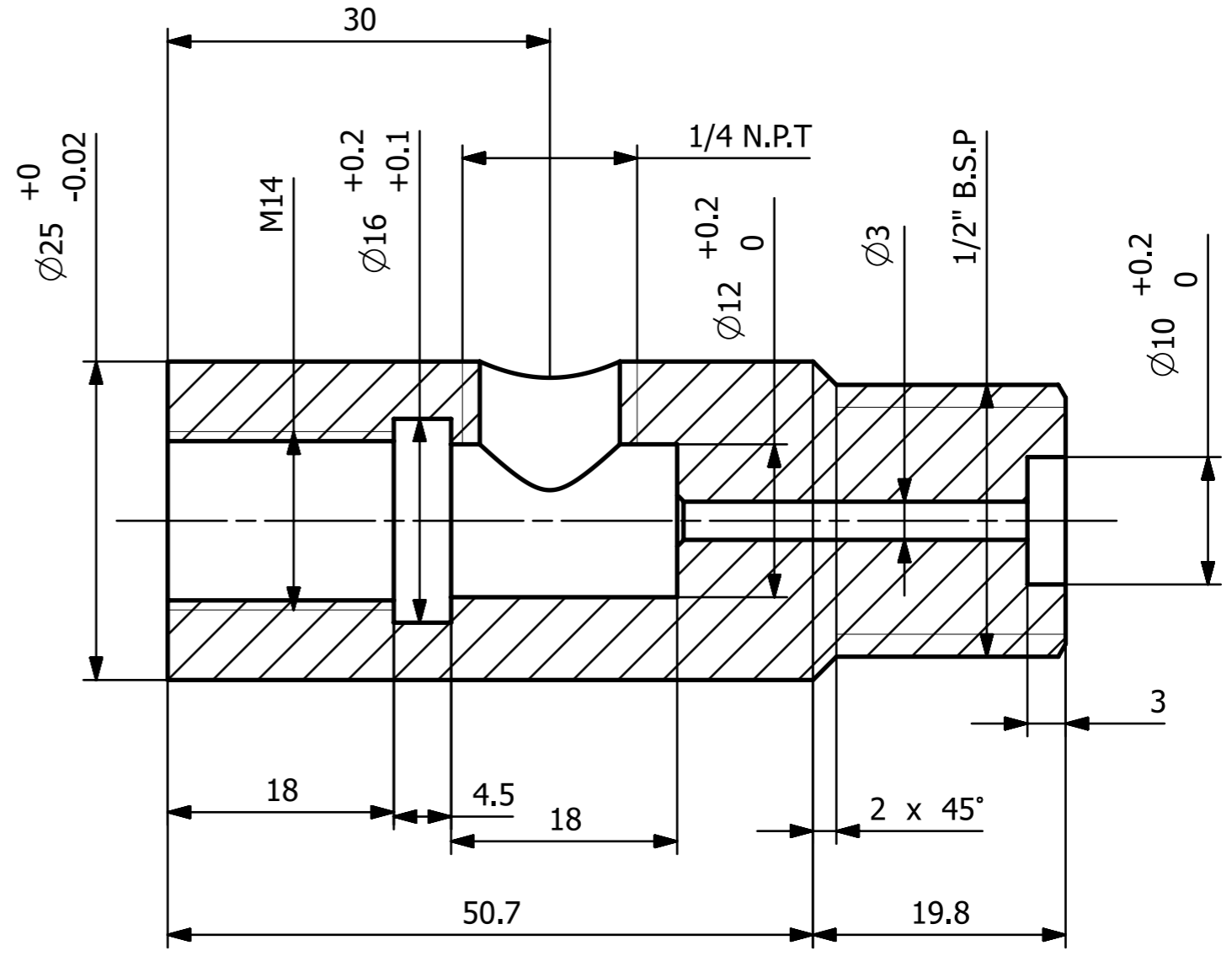

SECTION B-B

Permissible deviations for linear dimensions except for broken edges									
Tolerance class		0.5 upto 3	over 3 upto 6	over 6 upto 30	over 30 upto 120	over 120 upto 400	over 400 upto 1000	over 1000 upto 2000	over 2000 upto 4000
Designation	Description	±0.1	±0.1	±0.2	±0.3	±0.5	±0.8	±1.2	±2
m	medium								

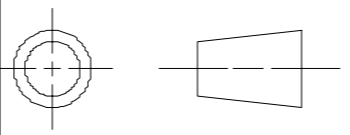

MATERIAL EN-24		I.I.T KANPUR		
FIRST ISSUED		TITLE		
DRAWN BY		Bleed Housing (Part No-27)		
CHECKED BY				
APPROVED BY		SIZE	DWG NO.	SHEET REV
		A3	BLEED_N-2020_dwg_1	A
SHEET 2 OF 2				